

---

# **EAST YORKSHIRE SOLAR FARM**

**East Yorkshire Solar Farm  
EN010143**

## **Environmental Statement**

**Volume 2, Appendix 13-5: Framework Construction Traffic Management Plan,  
Annex A: Proposed Access Layouts, Visibility Splays and Swept Paths (Part 2 of 3)  
Document Reference: EN010143/APP/6.2**

Regulation 5(2)(a)  
Infrastructure Planning (Applications: Prescribed Forms and Procedure)  
Regulations 2009

November 2023  
Revision Number: 00

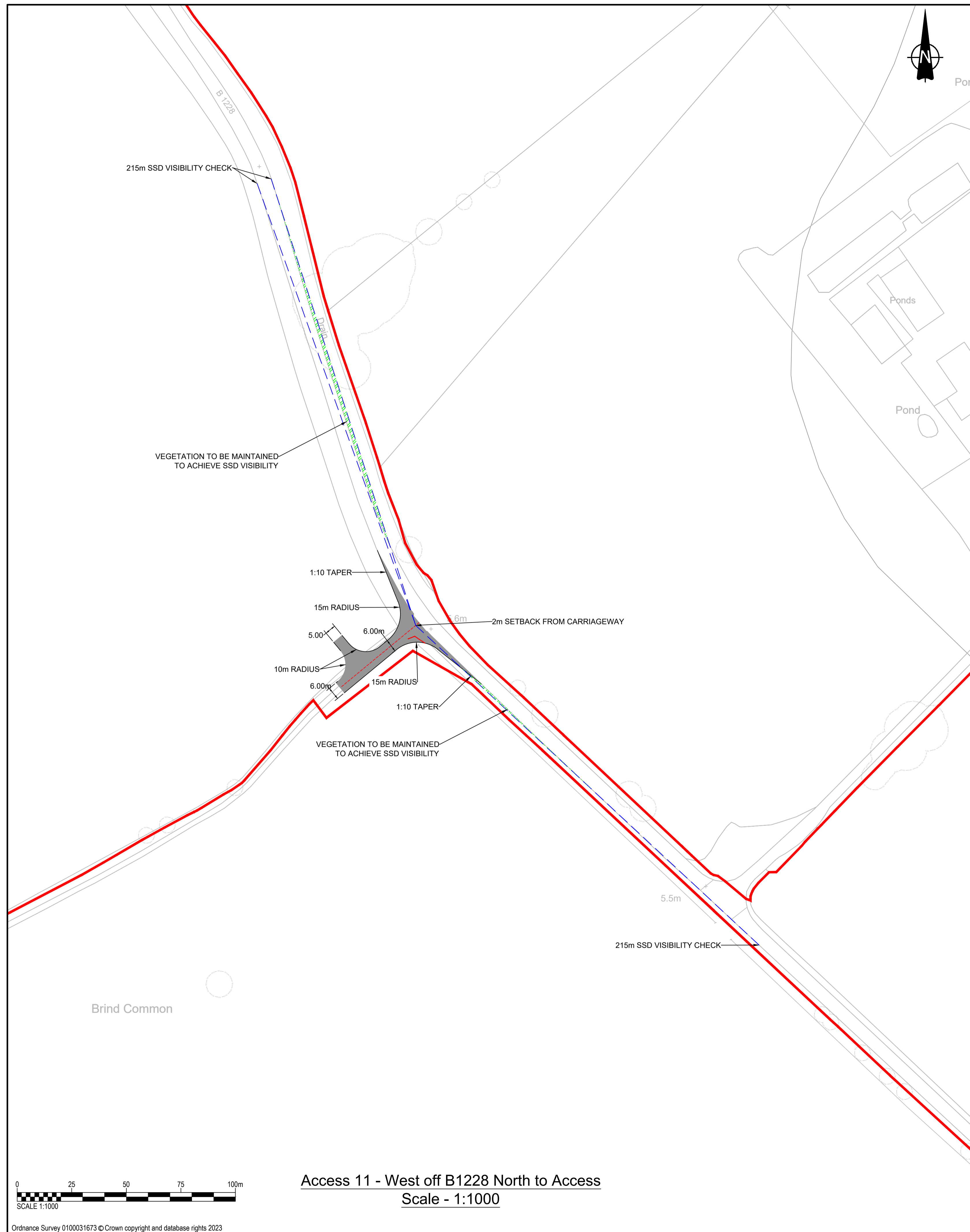

**Access 11 - West off B1228 North to Access**  
**Scale - 1:1000**

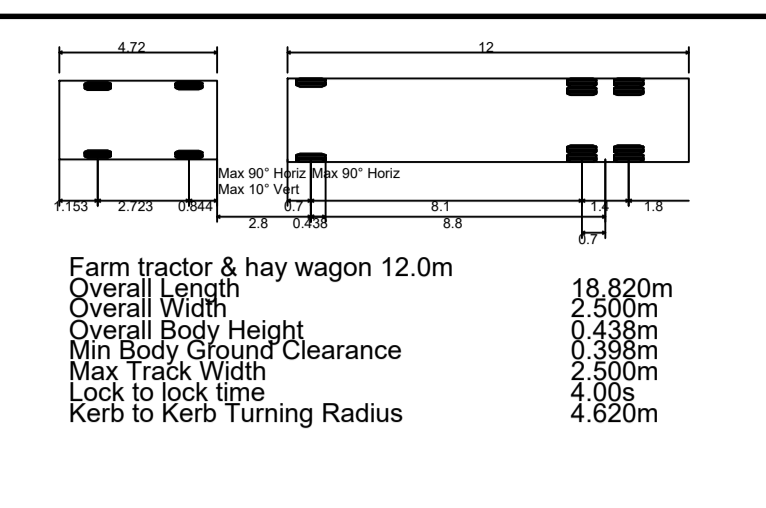
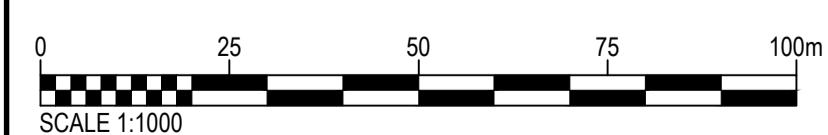

INSET A: TRACTOR & HAYWAGON MANOEUVRE HEADING SOUTH, RIGHT TURN INTO ACCESS - SCALE 1:1000

INSET B: TRACTOR & HAYWAGON MANOEUVRE HEADING NORTH, LEFT TURN INTO ACCESS - SCALE 1:1000

INSET C: TRACTOR & HAYWAGON MANOEUVRE HEADING EAST OUT OF ACCESS, RIGHT TURN HEADING SOUTH - SCALE 1:1000

INSET D: TRACTOR & HAYWAGON MANOEUVRE HEADING EAST OUT OF ACCESS, LEFT TURN HEADING NORTH - SCALE 1:1000



**PROJECT**  
 East Yorkshire Solar Farm  
 Development Consent Order

**CLIENT**  
 East Yorkshire Solar Farm Limited

**CONSULTANT**  
 AECOM  
 Saxon House, 27 Duke Street  
 Chelmsford, Essex, CM1 1HT  
 01245 771200 tel 01245 476121 fax  
 www.aecom.com

- GENERAL NOTES**
- This drawing is to be read in conjunction with all other relevant documentation.
  - Do not scale from this drawing, use only printed dimensions.
  - All dimensions in millimeters, all chainages, levels and coordinates are in meters unless defined otherwise.
  - This Drawing is to be read in conjunction with the project health & Safety File for any identified potential risks.
  - Vegetation to be removed denotes any vegetation features (such as hedgerows) that need to be removed to provide the required junction visibility. Any verge grassland is not to be removed but managed by the relevant maintainer to a low height so as to not impact upon junction visibility.
  - Junction Visibility for the access is based upon DMRB CD109 Table 2.10.
  - Passing place requirement and location subject to ongoing discussion and agreement with East Riding of Yorkshire.

- KEY**
- Extent of Access Footprint
  - Red Line Boundary
  - Existing Public Rights of Way
  - Vehicle body
  - Vehicle body path
  - Vehicle load
  - Vehicle load path
  - Vehicle wheels path
  - Vehicle wheels path
  - Edge of road
  - Land not included in the Order Limits
  - Junction Visibility
  - Vegetation Management for Vis Splay
  - Hedgerow Removal for Bellmouth Access

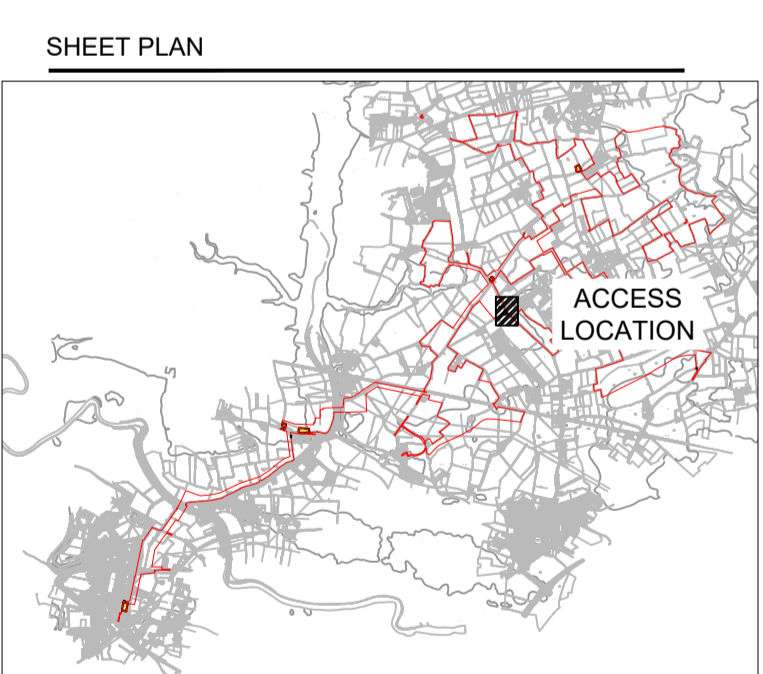

**ISSUE/REVISION**

NO	DATE	DESCRIPTION
P03	26-10-2023	Final DCO Submission
P02	15-09-2023	Updated Post Internal Review
P01	25-8-2023	Issued for Internal Review
I/R	DATE	DESCRIPTION

**PROJECT NUMBER**  
 60686115

**SHEET TITLE**  
 ACCESS 11 WEST OFF B1228 NORTH TO LAYOUT AND SWEPT PATH ANALYSIS

**SHEET NUMBER**  
 60686115-HGN-DR-CH-0111

This drawing has been prepared for the use of AECOM's client. It may not be used, modified, reproduced or relied upon by third parties, except as agreed by AECOM or as required by law. AECOM accepts no responsibility, and denies any liability whatsoever, to any party that uses or relies on this drawing without AECOM's express written consent. Do not scale this document.

Last saved by: CONROY, THOMAS (2023, 10, 27) Last Printed: 2023, 10, 31  
 Filename: C:\USERS\CONROY, THOMAS\AECOM\60686115-HGN-DR-CH-0112 P03.DWG  
 Project Management Initials: Designer: PG Checked: MP Approved: JCH  
 ISO A1 594mm x 841mm SCALE 1:1000

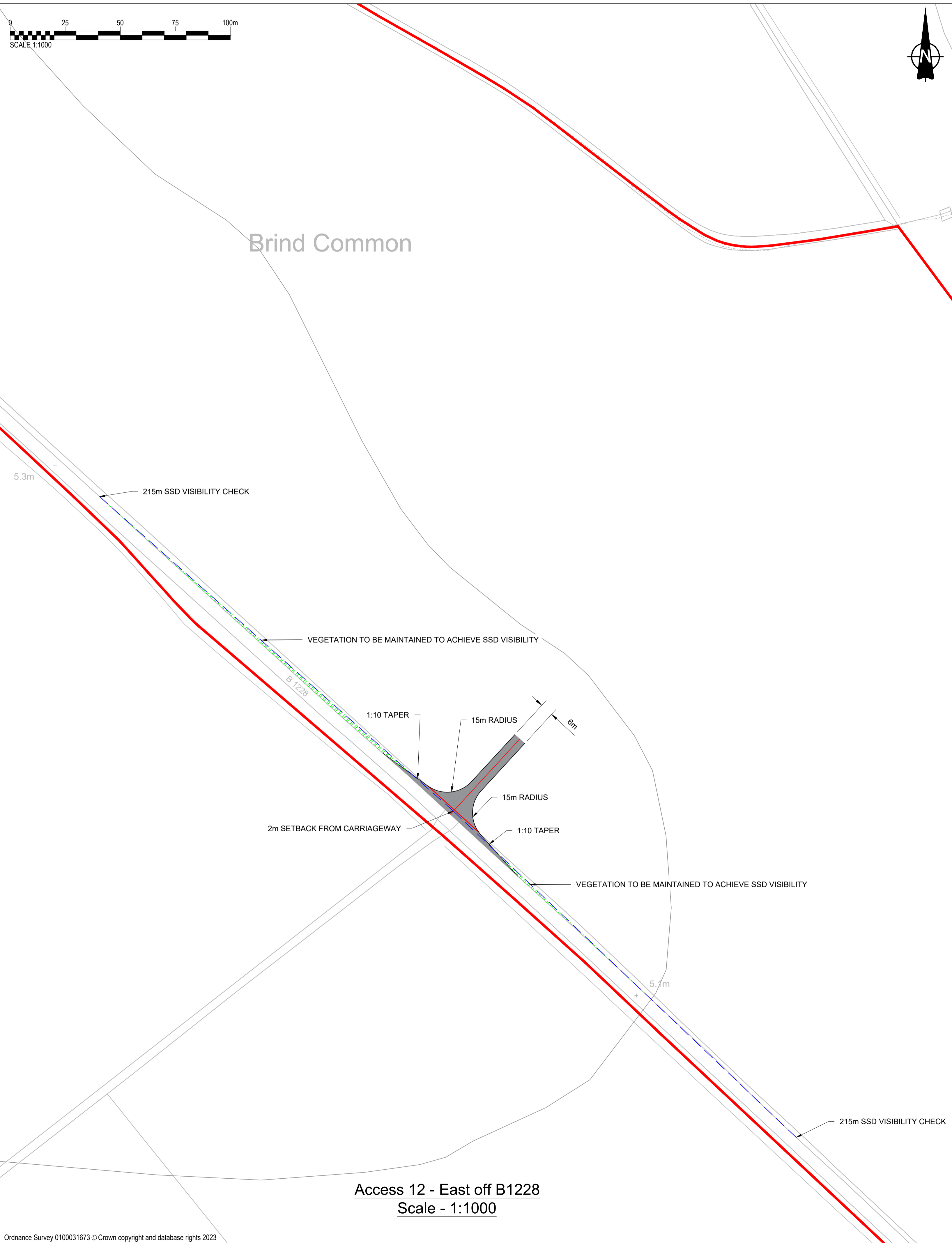

**Access 12 - East off B1228**  
Scale - 1:1000

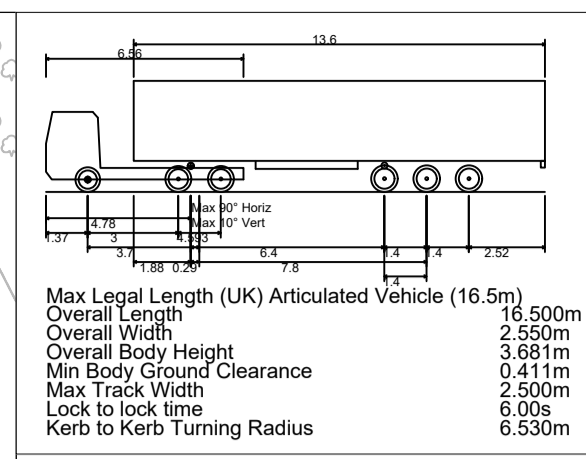

INSET A: HGV MANOEUVRE HEADING WEST ON B1228 STREET LANE, RIGHT TURN INTO ACCESS - SCALE 1:1000

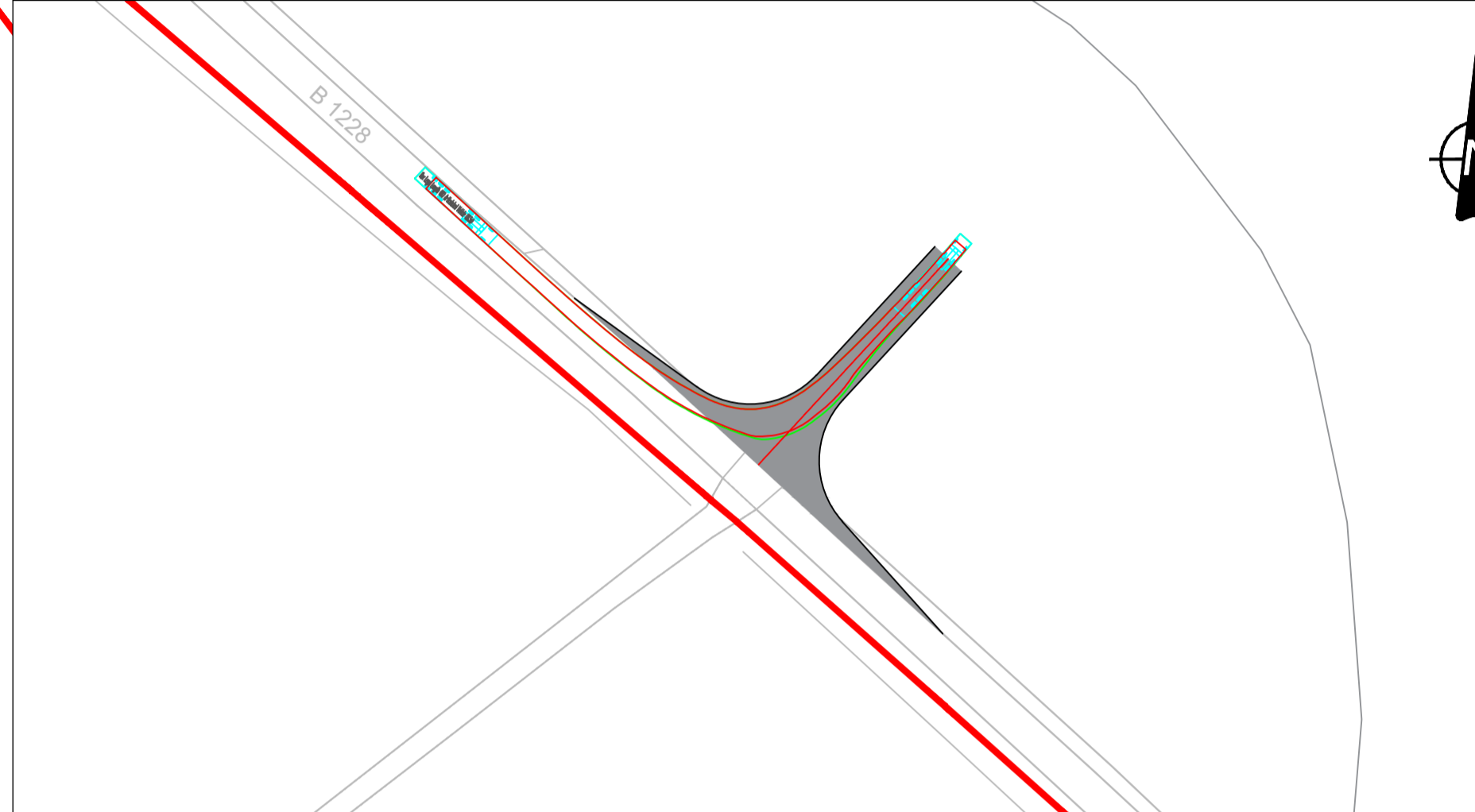

INSET B: HGV MANOEUVRE HEADING EAST ON B1228 STREET LANE, LEFT TURN INTO ACCESS - SCALE 1:1000

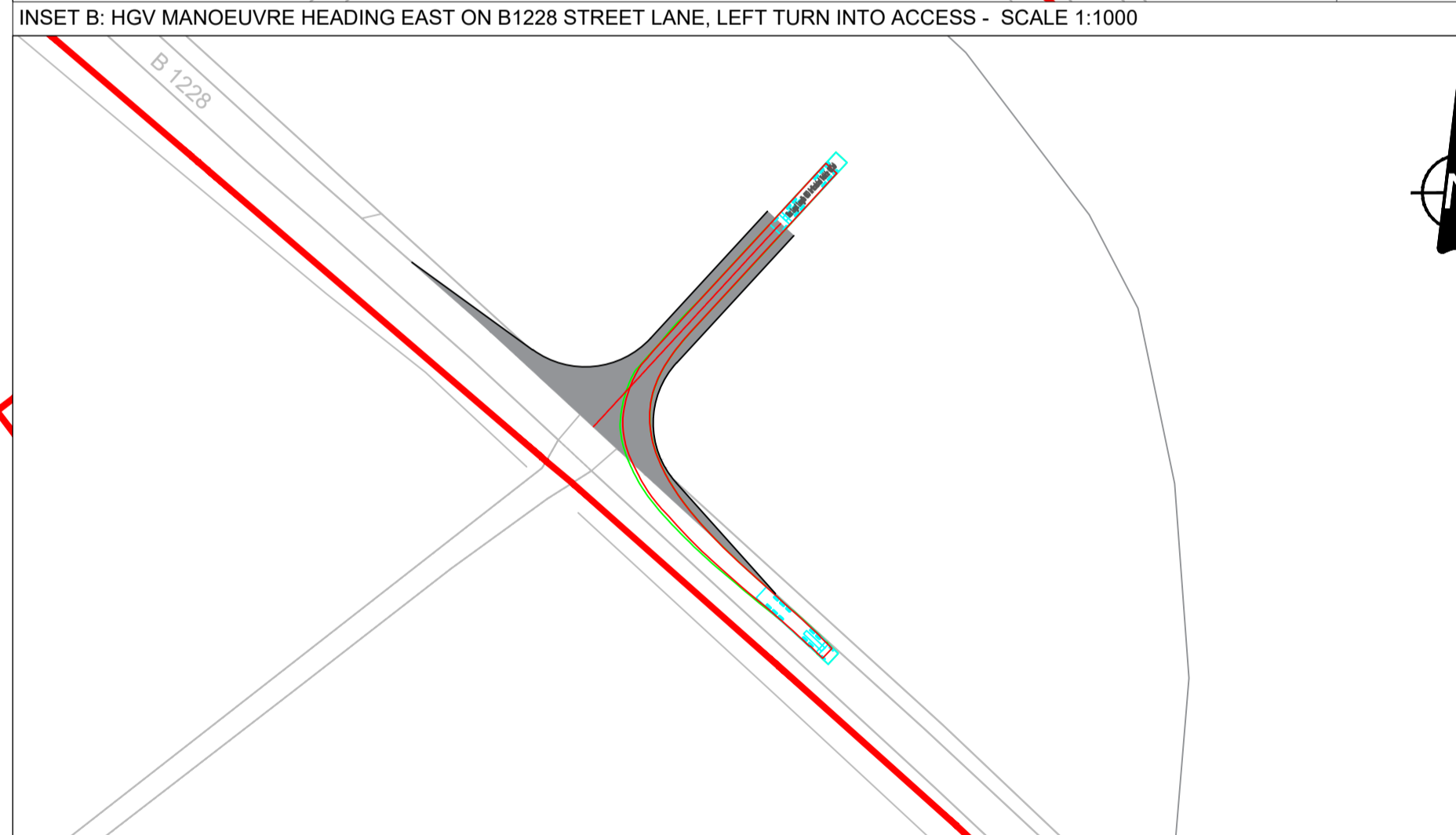

INSET C: HGV MANOEUVRE LEFT TURN OUT OF ACCESS, ONTO B1228 STREET LANE HEADING EAST - SCALE 1:1000

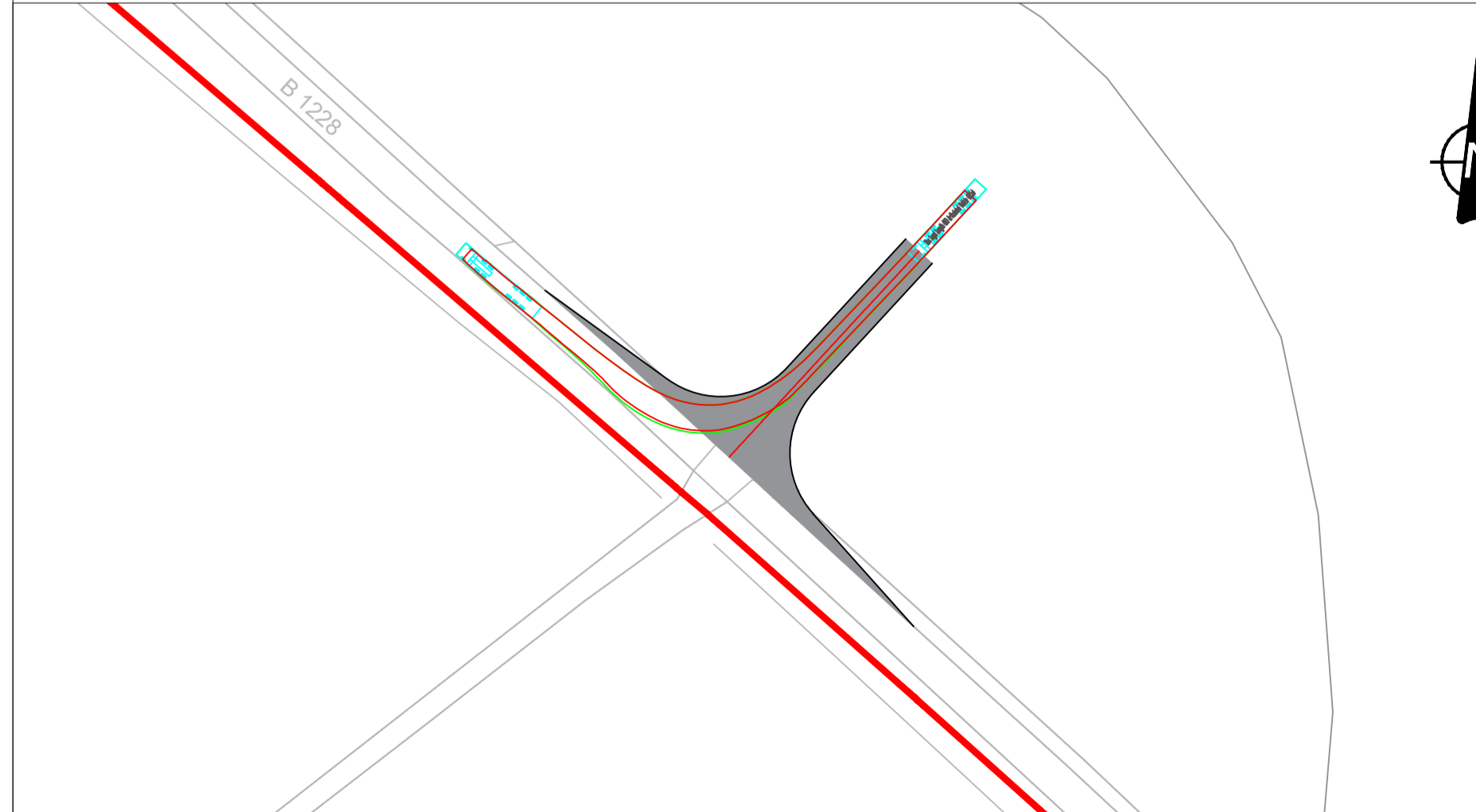

INSET D: HGV MANOEUVRE RIGHT TURN OUT OF ACCESS, ONTO B1228 STREET LANE HEADING WEST - SCALE 1:1000



**PROJECT**

East Yorkshire Solar Farm  
Development Consent Order

**CLIENT**

East Yorkshire Solar Farm Limited

**CONSULTANT**

AECOM  
Saxon House, 27 Duke Street  
Chelmsford, Essex, CM1 1HT  
01245 771200 tel 01245 476121 fax  
www.aecom.com

**GENERAL NOTES**

1. This drawing is to be read in conjunction with all other relevant documentation.
2. Do not scale from this drawing, use only printed dimensions.
3. All dimensions in millimeters, all chainages, levels and coordinates are in meters unless defined otherwise.
4. This Drawing is to be read in conjunction with the project health & Safety File for any identified potential risks.
5. Vegetation to be removed denotes any vegetation features (such as hedgerows) that need to be removed to provide the required junction visibility. Any verge grassland is not to be removed but managed by the relevant maintainer to a low height so as to not impact upon junction visibility.
6. Junction Visibility for the access is based upon DMRB CD109 Table 2.10.
7. Passing place requirement and location subject to ongoing discussion and agreement with East Riding of Yorkshire.

**KEY**

- Extent of Access Footprint
- Red Line Boundary
- Existing Public Rights of Way
- Vehicle body
- Vehicle body path
- Vehicle load
- Vehicle load path
- Vehicle wheels path
- Edge of road
- Land not included in the Order Limits
- Junction Visibility
- Vegetation Management for Vis Splay
- Hedgerow Removal for Bellmouth Access

**SHEET PLAN**



**ISSUE/REVISION**

I/R	DATE	DESCRIPTION
P03	26-10-2023	Final DCO Submission
P02	15-09-2023	Updated Post Internal Review
P01	25-08-2023	Issued for Internal Review

**PROJECT NUMBER**

60686115

**SHEET TITLE**

ACCESS 12 EAST OFF  
B1228 LAYOUT AND  
SWEEP PATH ANALYSIS

**SHEET NUMBER**

60686115-HGN-DR-CH-0112

This drawing has been prepared for the use of AECOM's client. It may not be used, modified, reproduced or relied upon by third parties, except as agreed by AECOM or as required by law. AECOM accepts no responsibility, and denies any liability whatsoever, to any party, that uses or relies on this drawing without AECOM's express written consent. Do not scale this document.

**GENERAL NOTES**

1. This drawing is to be read in conjunction with all other relevant documentation.
2. Do not scale from this drawing, use only printed dimensions.
3. All dimensions in millimeters, all chainages, levels and coordinates are in meters unless defined otherwise.
4. This Drawing is to be read in conjunction with the project health & Safety File for any identified potential risks.
5. Vegetation to be removed denotes any vegetation features (such as hedgerows) that need to be removed to provide the required junction visibility. Any verge grassland is not to be removed but managed by the relevant maintainer to a low height so as to not impact upon junction visibility.
6. Junction Visibility for the access is based upon DMRB CD109 Table 2.10.
7. Passing place requirement and location subject to ongoing discussion and agreement with East Riding of Yorkshire.

**KEY**

- Extent of Access Footprint
- Red Line Boundary
- Existing Public Rights of Way
- Vehicle body
- Vehicle body path
- Vehicle load
- Vehicle load path
- Vehicle wheels path
- Edge of road
- Land not included in the Order Limits
- Junction Visibility
- Vegetation management for Vis Splay
- Hedgerow Removal for Vis Splay
- Hedgerow Removal for Bellmouth Access

**SHEET PLAN**

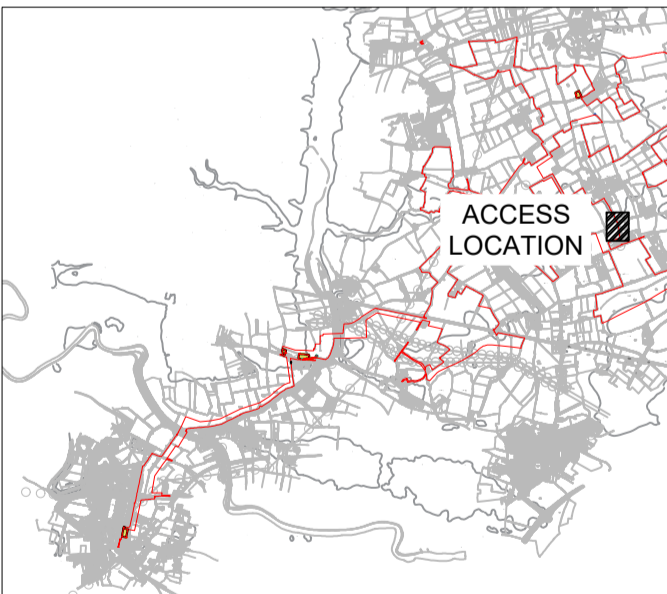

**ISSUE/REVISION**

NO	DATE	DESCRIPTION
P03	27-10-2023	Final DCO Submission
P02	15-09-2023	Updated Post Internal Review
P01	25-08-2023	Issued for Internal Review
I/R	DATE	DESCRIPTION

**PROJECT NUMBER**

60686115

**SHEET TITLE**

ACCESS 13 WEST OFF WILLITTOFT ROAD ACCESS LAYOUT AND SWEEP PATH ANALYSIS

**SHEET NUMBER**

60686115-HGN-DR-CH-0113

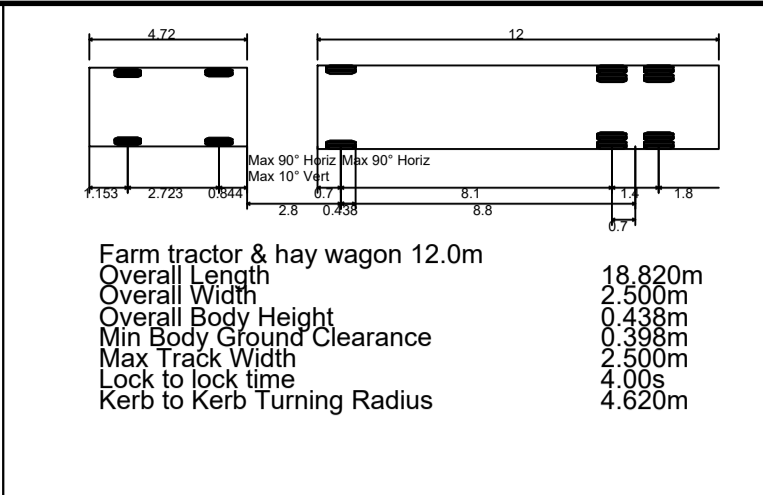

INSET A: TRACTOR & HAYWAGON MANOEUVRE HEADING SOUTH ON WILLITTOFT ROAD, RIGHT TURN INTO ACCESS - SCALE 1:1000

INSET B: TRACTOR & HAY WAGON MANOEUVRE HEADING NORTH ON WILLITTOFT ROAD, LEFT TURN INTO ACCESS - SCALE 1:1000

INSET C: TRACTOR & HAY WAGON MANOEUVRE HEADING EAST OUT OF ACCESS, LEFT TURN HEADING NORTH - SCALE 1:1000

INSET D: TRACTOR & HAYWAGON MANOEUVRE HEADING EAST OUT OF ACCESS, RIGHT TURN HEADING SOUTH - SCALE 1:1000

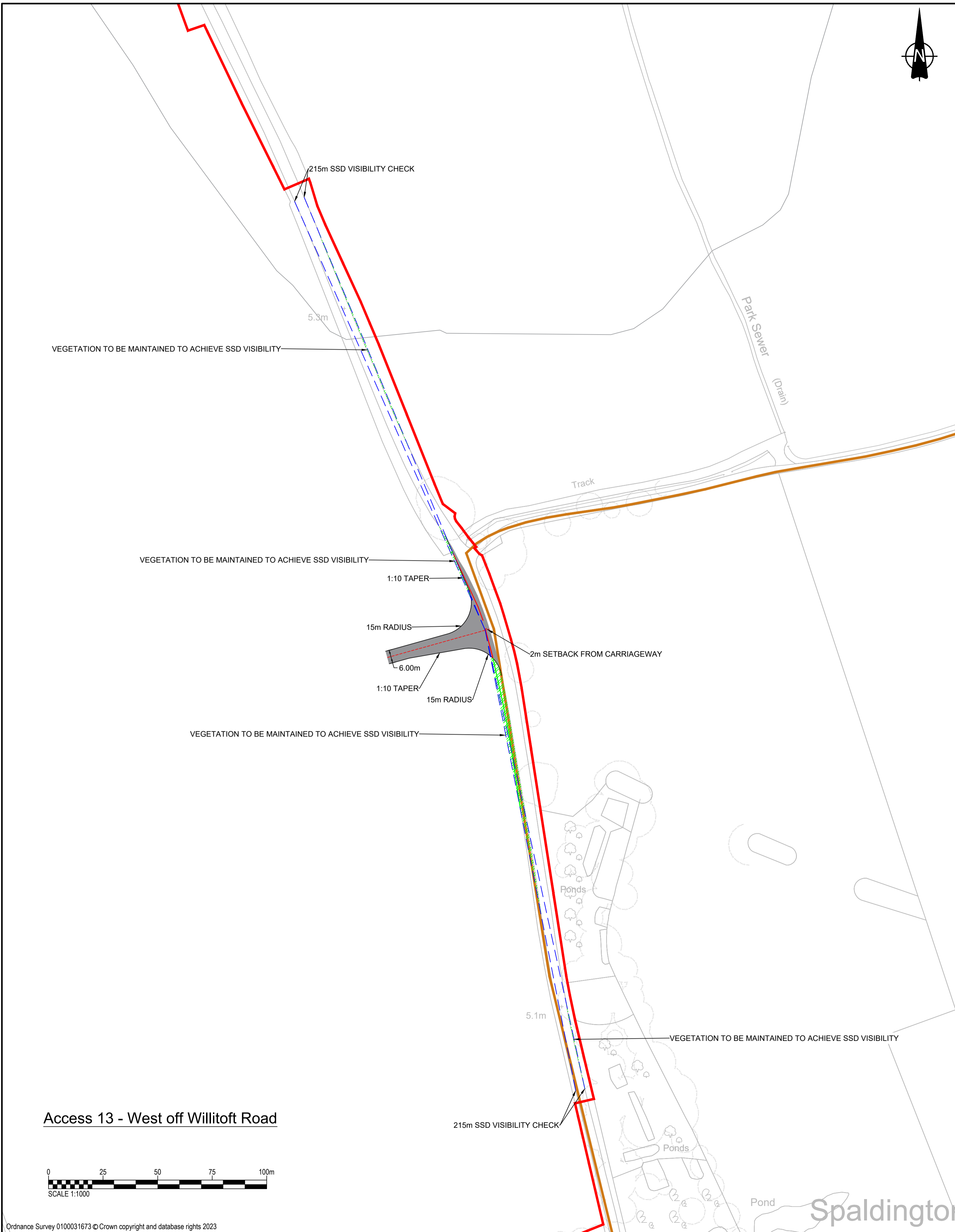

Access 13 - West off Willitoff Road

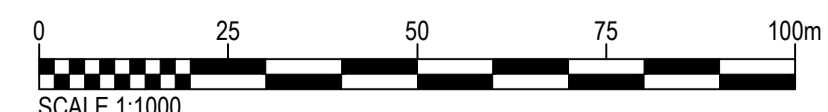

This drawing has been prepared for the use of AECOM's client. It may not be used, modified, reproduced or relied upon by third parties, except as agreed by AECOM or as required by law. AECOM accepts no responsibility, and denies any liability whatsoever, to any party that uses or relies on this drawing without AECOM's express written consent. Do not scale this document.



Access 14 - South off Spaldington Lane  
Scale - 1:1000

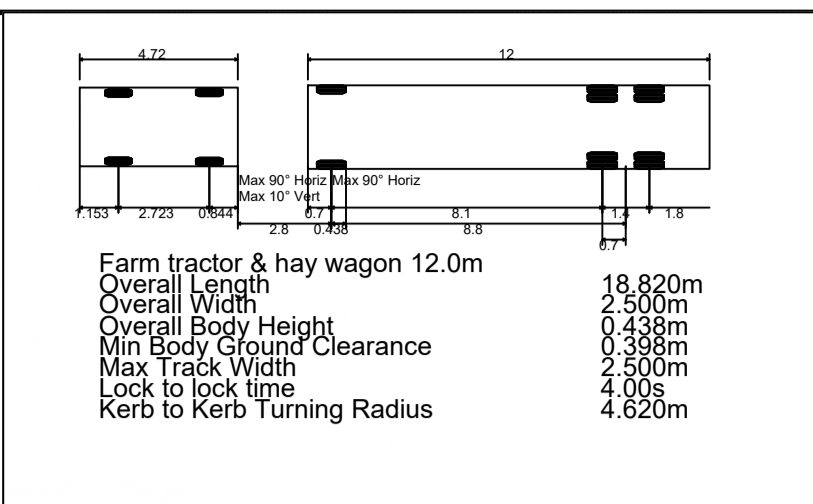
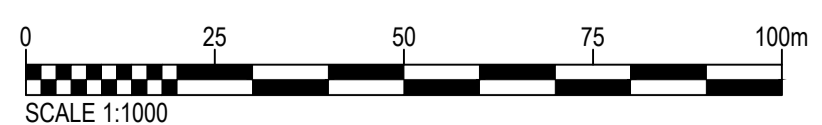

INSET A: FARM TRACTOR AND HAY WAGON MANOEUVRE HEADING EAST ON SPALDINGTON LANE, RIGHT TURN INTO ACCESS - SCALE 1:1000

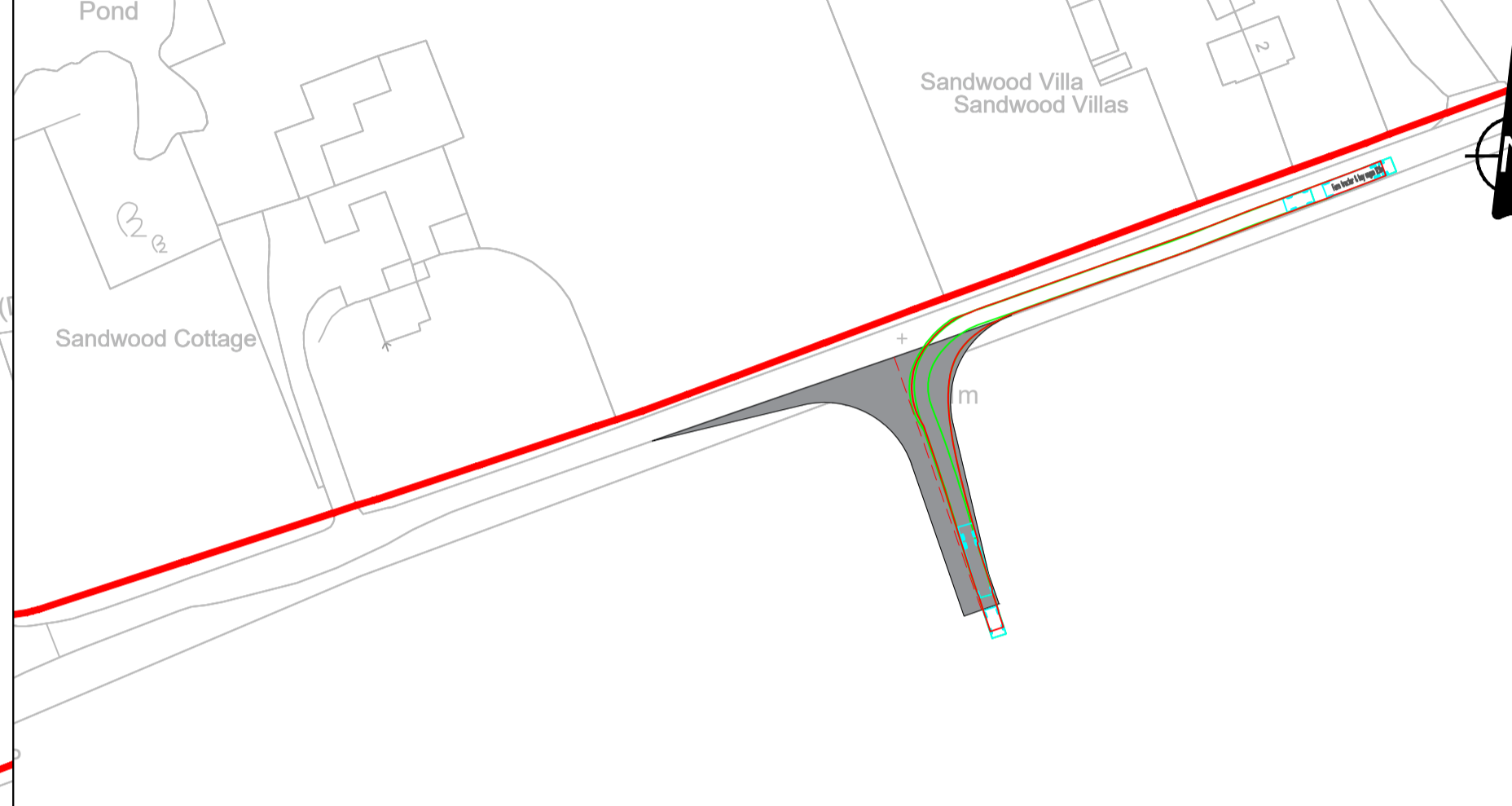

INSET B: FARM TRACTOR AND HAY WAGON MANOEUVRE HEADING WEST ON SPALDINGTON LANE, LEFT TURN INTO ACCESS - SCALE 1:1000

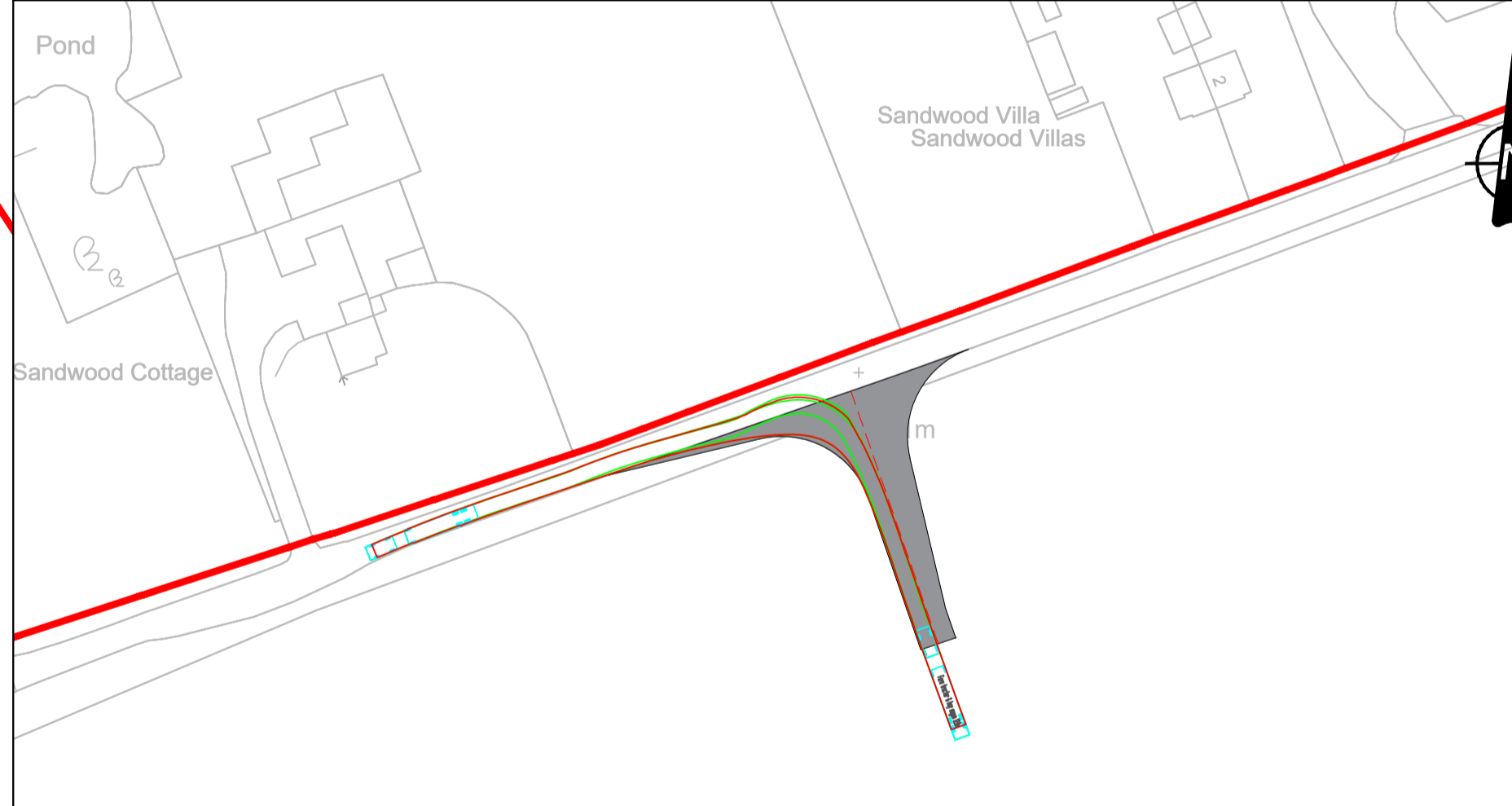

INSET C: FARM TRACTOR AND HAY WAGON MANOEUVRE LEFT TURN OUT OF ACCESS ONTO SPALDINGTON LANE HEADING WEST - SCALE 1:1000

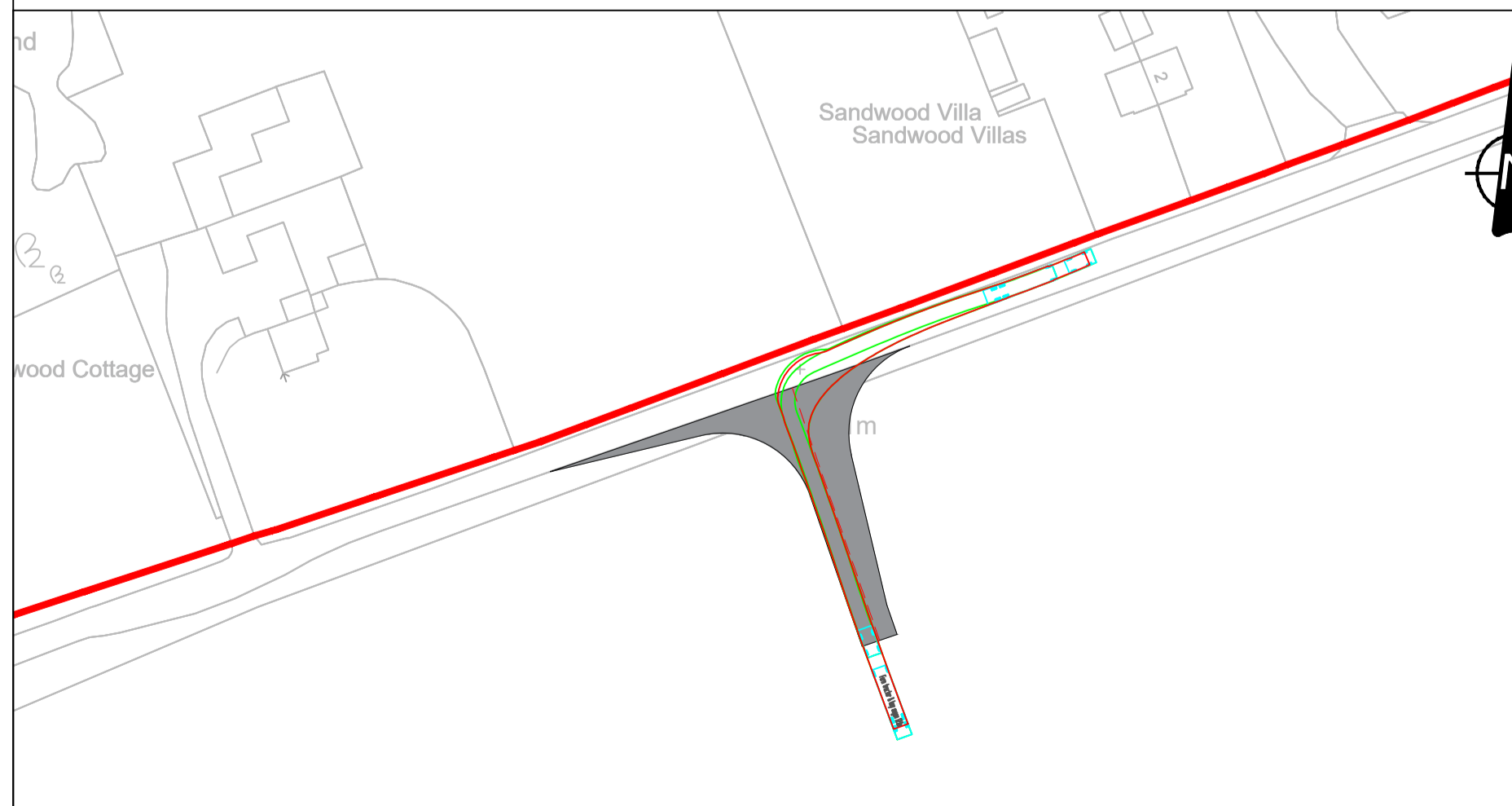

INSET D: FARM TRACTOR AND HAY WAGON MANOEUVRE RIGHT TURN OUT OF ACCESS ONTO SPALDINGTON LANE HEADING EAST - SCALE 1:1000

- GENERAL NOTES**
1. This drawing is to be read in conjunction with all other relevant documentation.
  2. Do not scale from this drawing, use only printed dimensions.
  3. All dimensions in millimeters, all chainages, levels and coordinates are in meters unless defined otherwise.
  4. This Drawing is to be read in conjunction with the project health & Safety File for any identified potential risks.
  5. Vegetation to be removed denotes any vegetation features (such as hedgerows) that need to be removed to provide the required junction visibility. Any verge grassland is not to be removed but managed by the relevant maintainer to a low height so as to not impact upon junction visibility.
  6. Junction visibility for the access is based upon visibility parameters derived using 85th Percentile Speed Survey received on 27th July 2023.
  7. Passing place requirement and location subject to ongoing discussion and agreement with East Riding of Yorkshire.

- KEY**
- Extent of Access Footprint
  - Red Line Boundary
  - Existing Public Rights of Way
  - Vehicle body
  - Vehicle body path
  - Vehicle load
  - Vehicle load path
  - Vehicle wheels path
  - Edge of road
  - Land not included in the Order Limits
  - Junction Visibility
  - Vegetation Management for Vis Splay
  - Hedgerow Removal for Bellmouth Access

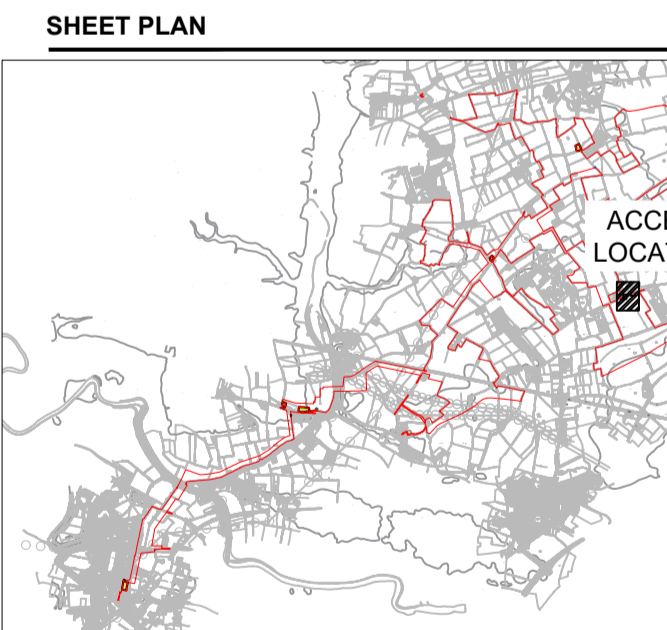

**ISSUE/REVISION**

NO	DATE	DESCRIPTION
P03	27-10-2023	Final DCO Submission
P02	15-09-2023	Updated Post Internal Review
P01	29-08-2023	Issued for Internal Review
I/R	DATE	DESCRIPTION

This drawing has been prepared for the use of AECOM's client. It may not be used, modified, reproduced or relied upon by third parties, except as agreed by AECOM or as required by law. AECOM accepts no responsibility, and denies any liability whatsoever, to any party that uses or relies on this drawing without AECOM's express written consent. Do not scale this document.

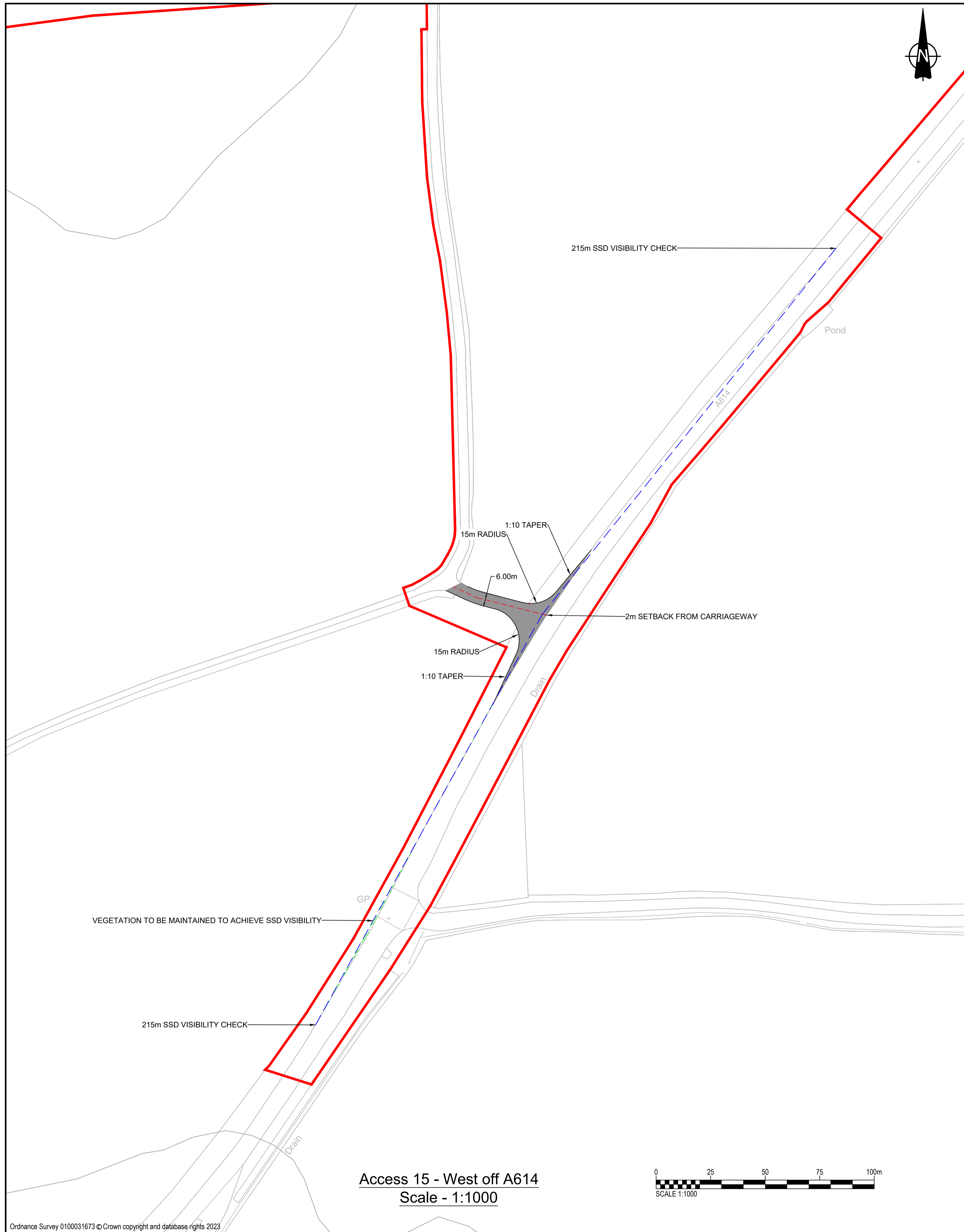

Farm tractor & hay wagon	12.0m
Overall Length	18.820m
Overall Width	2.500m
Overall Body Height	0.438m
Min Body Ground Clearance	0.398m
Max Track Width	2.500m
Lock to lock time	4.00s
Kerb to Kerb Turning Radius	4.620m

INSET A: TRACTOR & HAY WAGON MANOEUVRE HEADING NORTH ON THE A614, LEFT TURN INTO ACCESS - SCALE 1:1000

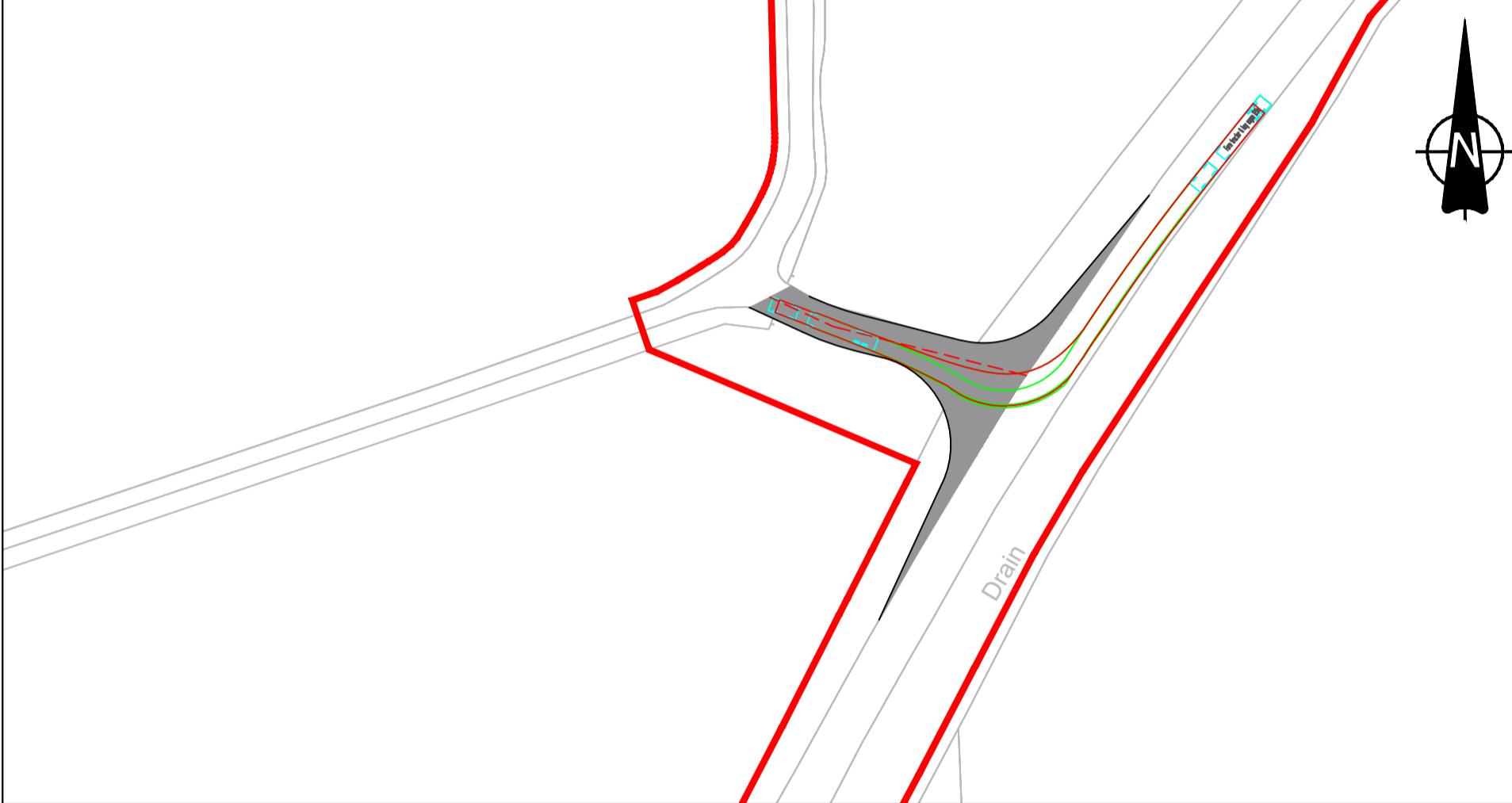

INSET B: TRACTOR & HAY WAGON MANOEUVRE HEADING SOUTH ON THE A614, RIGHT TURN INTO ACCESS - SCALE 1:1000

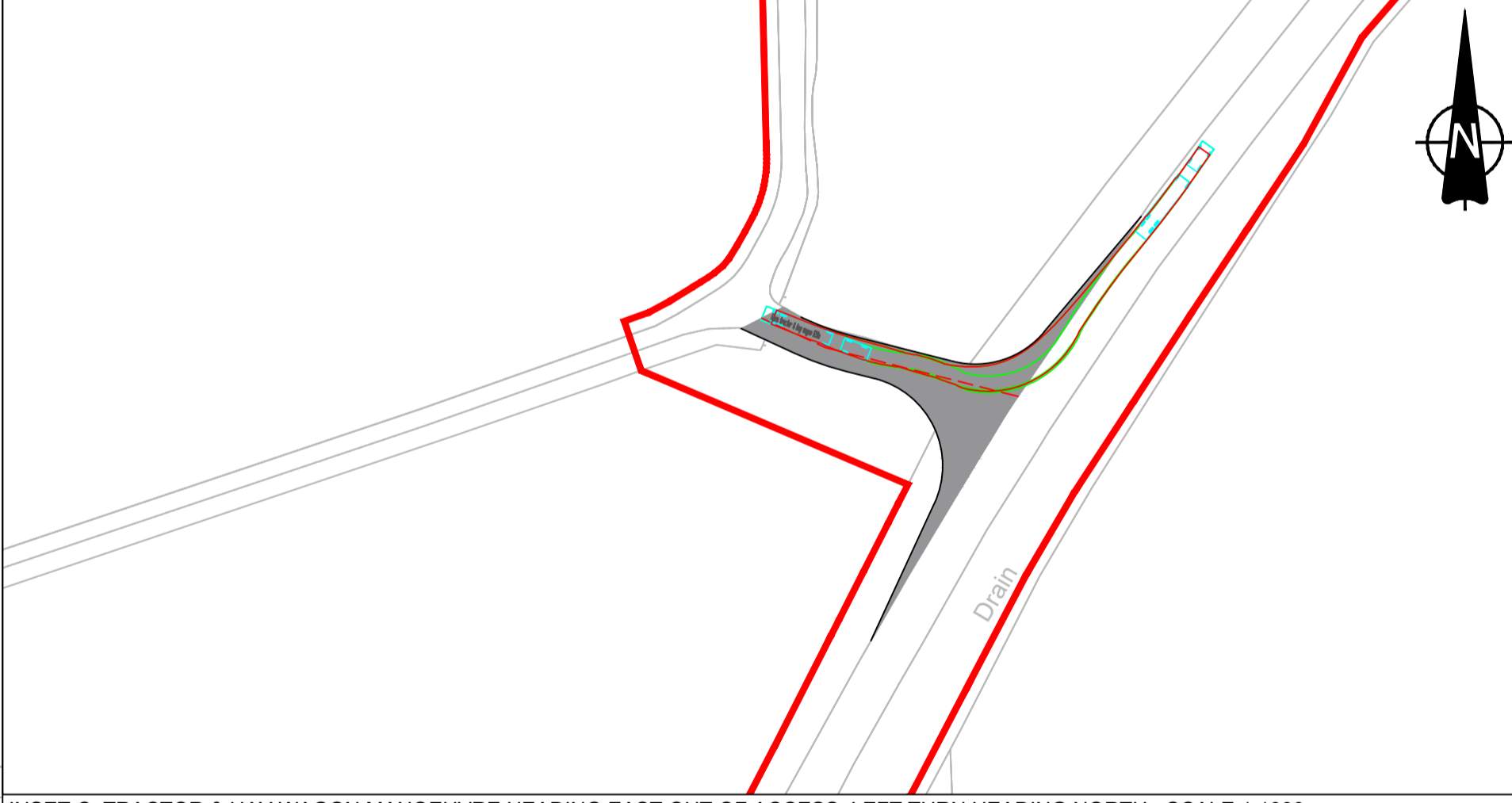

INSET C: TRACTOR & HAY WAGON MANOEUVRE HEADING EAST OUT OF ACCESS, LEFT TURN HEADING NORTH - SCALE 1:1000

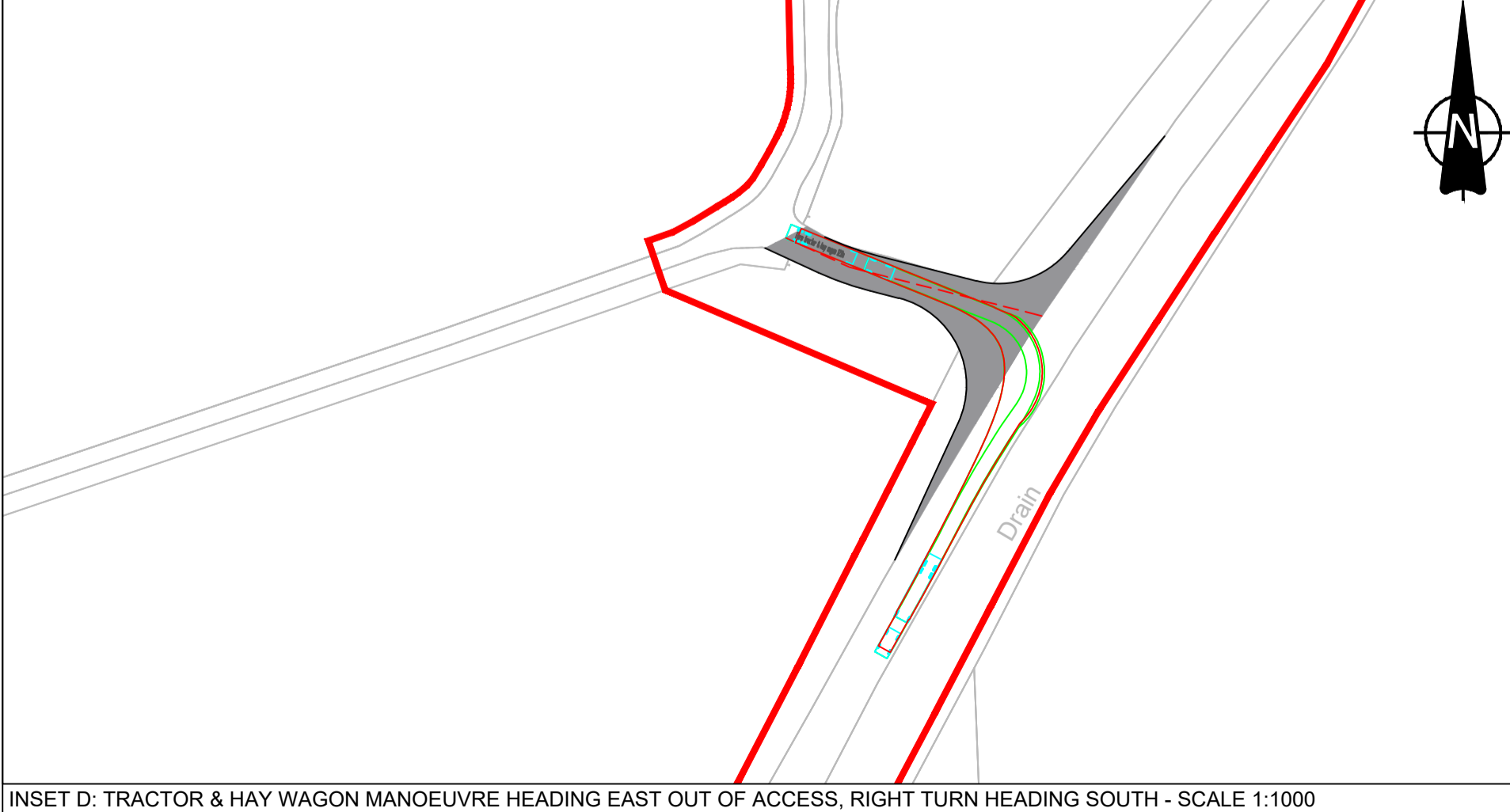

INSET D: TRACTOR & HAY WAGON MANOEUVRE HEADING EAST OUT OF ACCESS, RIGHT TURN HEADING SOUTH - SCALE 1:1000

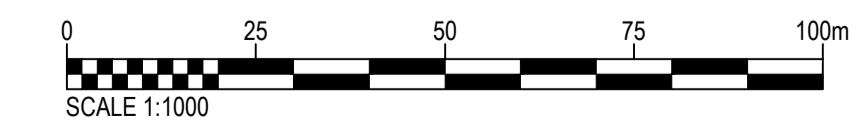

- GENERAL NOTES**
1. This drawing is to be read in conjunction with all other relevant documentation.
  2. Do not scale from this drawing, use only printed dimensions.
  3. All dimensions in millimeters, all chainages, levels and coordinates are in meters unless defined otherwise.
  4. This Drawing is to be read in conjunction with the project health & Safety File for any identified potential risks.
  5. Vegetation to be removed denotes any vegetation features (such as hedgerows) that need to be removed to provide the required junction visibility. Any verge grassland is not to be removed but managed by the relevant maintainer to a low height so as to not impact upon junction visibility.
  6. Junction Visibility for the access is based upon DMRB CD109 Table 2.10.
  7. Passing place requirement and location subject to ongoing discussion and agreement with East Riding of Yorkshire.

- KEY**
- Extent of Access Footprint
  - Red Line Boundary
  - Existing Public Rights of Way
  - Vehicle body
  - Vehicle body path
  - Vehicle load
  - Vehicle load path
  - Vehicle wheels path
  - Edge of road
  - Land not included in the Order Limits
  - Junction Visibility
  - Vegetation Management for Vis Splay
  - Hedgerow Removal for Bellmouth Access

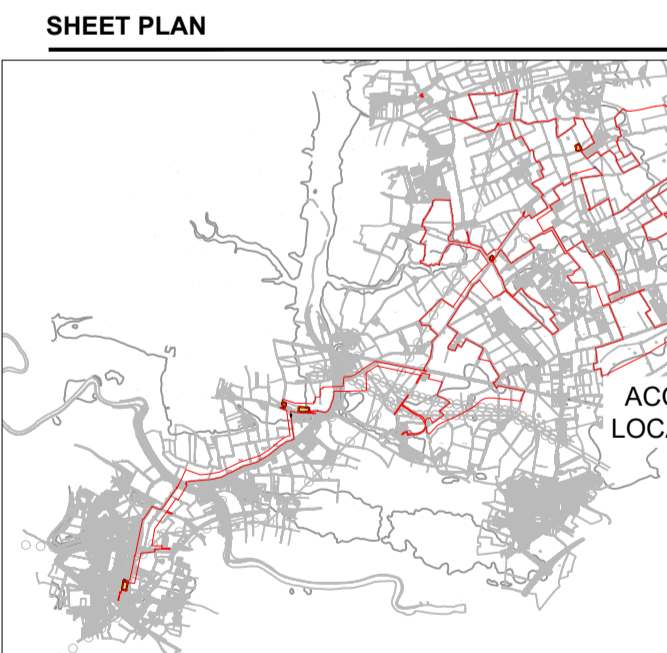

**ISSUE/REVISION**

I/R	DATE	DESCRIPTION
P03	27-10-2023	Final DCO Submission
P02	15-09-2023	Updated Post Internal Review
P01	25-08-2023	Issued for Internal Review

**PROJECT NUMBER**  
 60686115

**SHEET TITLE**  
 ACCESS 15 WEST OFF A614  
 LAYOUT AND  
 SWEEP PATH ANALYSIS

**SHEET NUMBER**  
 60686115-HGN-DR-CH-0115

This drawing has been prepared for the use of AECOM's client. It may not be used, modified, reproduced or relied upon by third parties, except as agreed by AECOM or as required by law. AECOM accepts no responsibility, and denies any liability whatsoever, to any party that uses or relies on this drawing without AECOM's express written consent. Do not scale this document.

Last saved by: CONROY, THOMAS (2023, 11, 02) Last Printed: 2023, 11, 02  
 Filename: C:\USERS\CONROY, THOMAS\AECOM\60686115\HGN-DR-CH-0116\BOOM POWER SOLAR DCO - GENERAL\900\_CAD\_GIS\910\_CAD\IEVSF - HIGHWAYS CAD\DRAWINGS (CAD)\ACCESS DRAWINGS P03060686115-HGN-DR-CH-0116 P03.DWG  
 Project Management Initials: Designer: PG Checked: MP Approved: JCH ISO At 594mm x 841mm

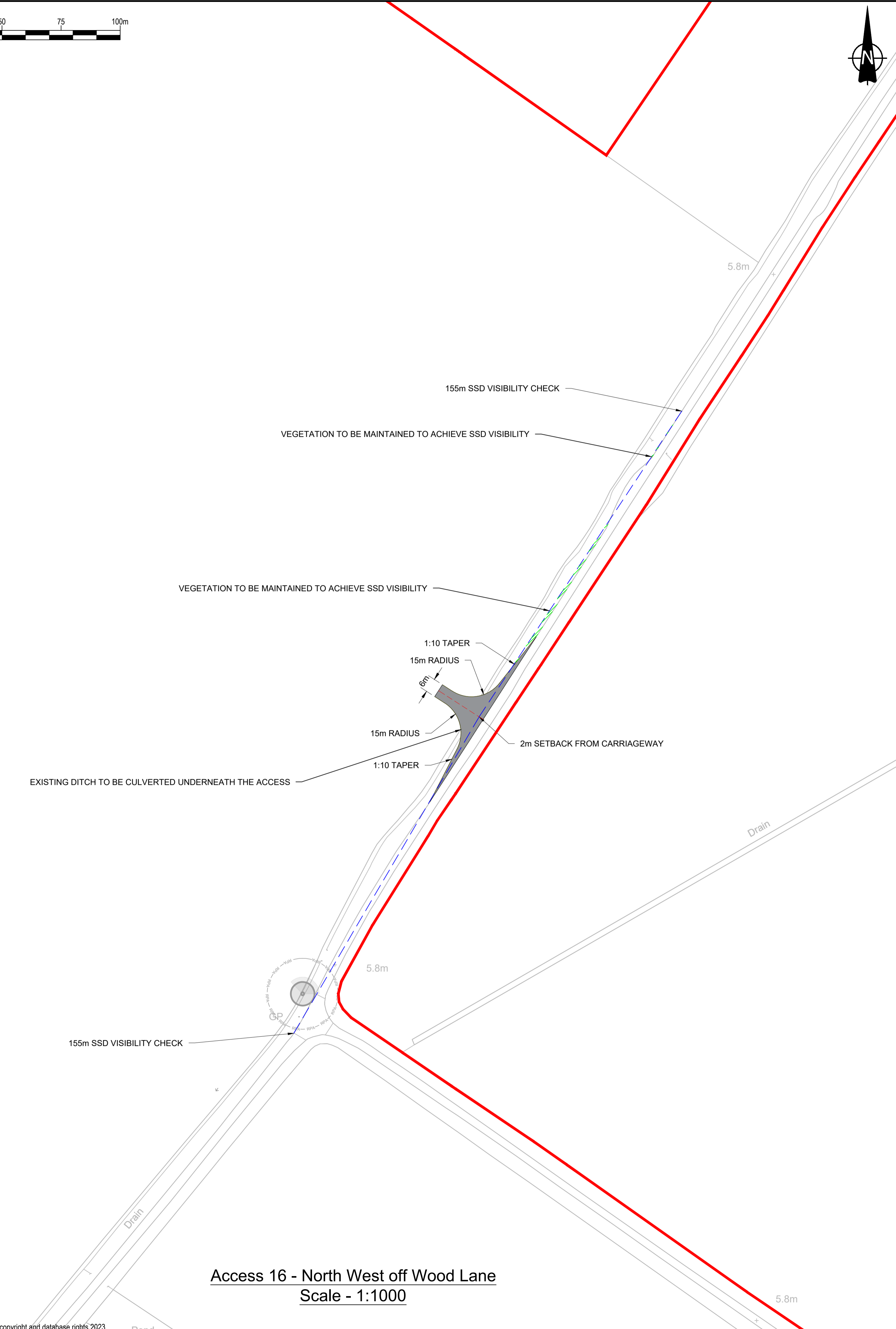
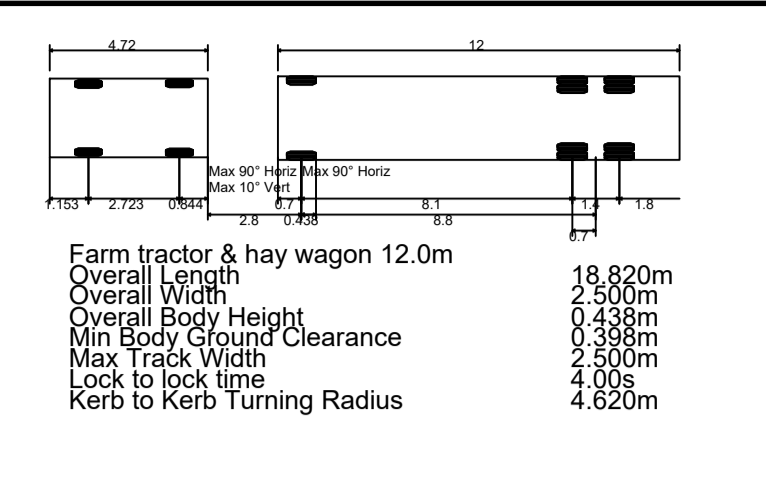
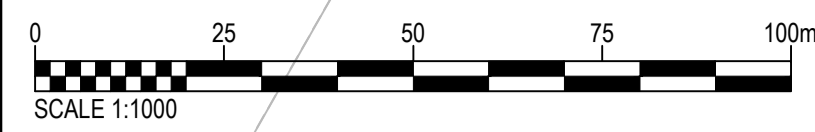

**Access 16 - North West off Wood Lane**  
Scale - 1:1000

INSET A: FARM TRACTOR AND HAY TRAILER MANOEUVRE HEADING SOUTH ON WOOD LANE, RIGHT TURN INTO ACCESS - SCALE 1:1000

INSET B: FARM TRACTOR AND HAY TRAILER MANOEUVRE HEADING NORTH ON WOOD LANE, LEFT TURN INTO ACCESS - SCALE 1:1000

INSET C: FARM TRACTOR AND HAY TRAILER MANOEUVRE LEFT TURN OUT OF ACCESS ONTO WOOD LANE HEADING NORTH - SCALE 1:1000

INSET D: FARM TRACTOR AND HAY TRAILER MANOEUVRE RIGHT TURN OUT OF ACCESS ONTO WOOD LANE HEADING SOUTH - SCALE 1:1000



**PROJECT**  
East Yorkshire Solar Farm  
Development Consent Order

**CLIENT**  
EAST YORKSHIRE SOLAR FARM LIMITED

**CONSULTANT**  
AECOM  
Saxon House, 27 Duke Street  
Chelmsford, Essex, CM1 1HT  
01245 771200 tel 01245 476121 fax  
www.aecom.com

- GENERAL NOTES**
1. This drawing is to be read in conjunction with all other relevant documentation. Do not scale from this drawing, use only printed dimensions.
  2. Do not scale from this drawing, use only printed dimensions.
  3. All dimensions in millimeters, all chainages, levels and coordinates are in meters unless defined otherwise.
  4. This Drawing is to be read in conjunction with the project health & Safety File for any identified potential risks.
  5. Vegetation to be removed denotes any vegetation features (such as hedgerows) that need to be removed to provide the required junction visibility. Any verge grassland is not to be removed but managed by the relevant maintainer to a low height so as to not impact upon junction visibility.
  6. Junction visibility for the access is based upon visibility parameters derived using 85th Percentile Speed Survey received on 27th July 2023.
  7. Passing place requirement and location subject to ongoing discussion and agreement with East Riding of Yorkshire.

- KEY**
- Extent of Access Footprint
  - Red Line Boundary
  - Existing Public Rights of Way
  - Vehicle body
  - Vehicle body path
  - Vehicle load
  - Vehicle load path
  - Vehicle wheels path
  - Edge of road
  - Land not included in the Order Limits
  - Junction Visibility
  - Vegetation Management for Vis Splay

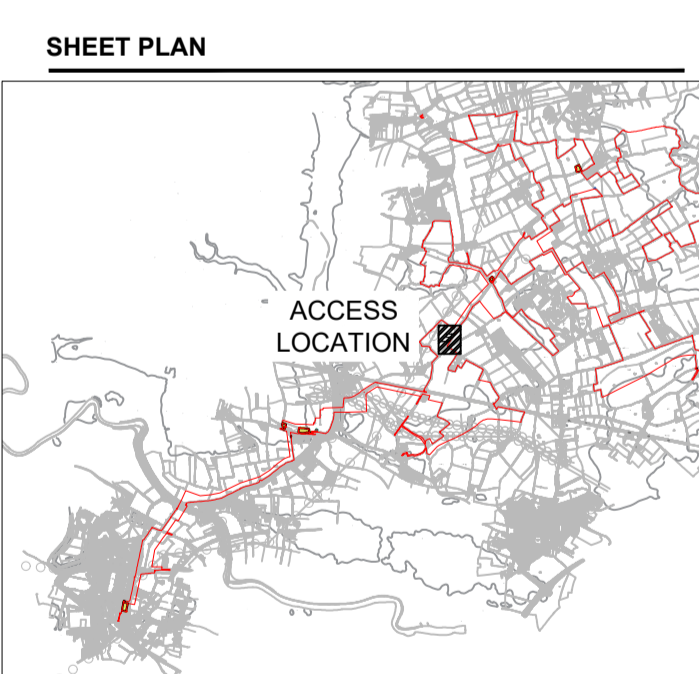

**ISSUE/REVISION**

NO	DATE	DESCRIPTION
P03	27-10-2023	Final DCO Submission
P02	15-09-2023	Updated Post Internal Review
P01	25-08-2023	Issued for internal review
I/R	DATE	DESCRIPTION

**PROJECT NUMBER**  
60686115

**SHEET TITLE**  
ACCESS 16 NORTH WEST OFF WOOD LANE LAYOUT AND SWEEP PATH ANALYSIS

**SHEET NUMBER**  
60686115-HGN-DR-CH-0116

This drawing has been prepared for the use of AECOM's client. It may not be used, modified, reproduced or relied upon by third parties, except as agreed by AECOM or as required by law. AECOM accepts no responsibility, and denies any liability whatsoever, to any party, that uses or relies on this drawing without AECOM's express written consent. Do not scale this document.

ISO A1 594mm x 841mm  
 Approved: JCH  
 Checked: MP  
 Designer: PG  
 Project Management Initials:  
 Last saved by: CONROY, THOMAS(2023,11,01) Last Printed: 2023,11,01  
 Filename: C:\USERS\CONROY, THOMAS\AECOM\60686115-HGN-DR-CH-0117 P03.DWG

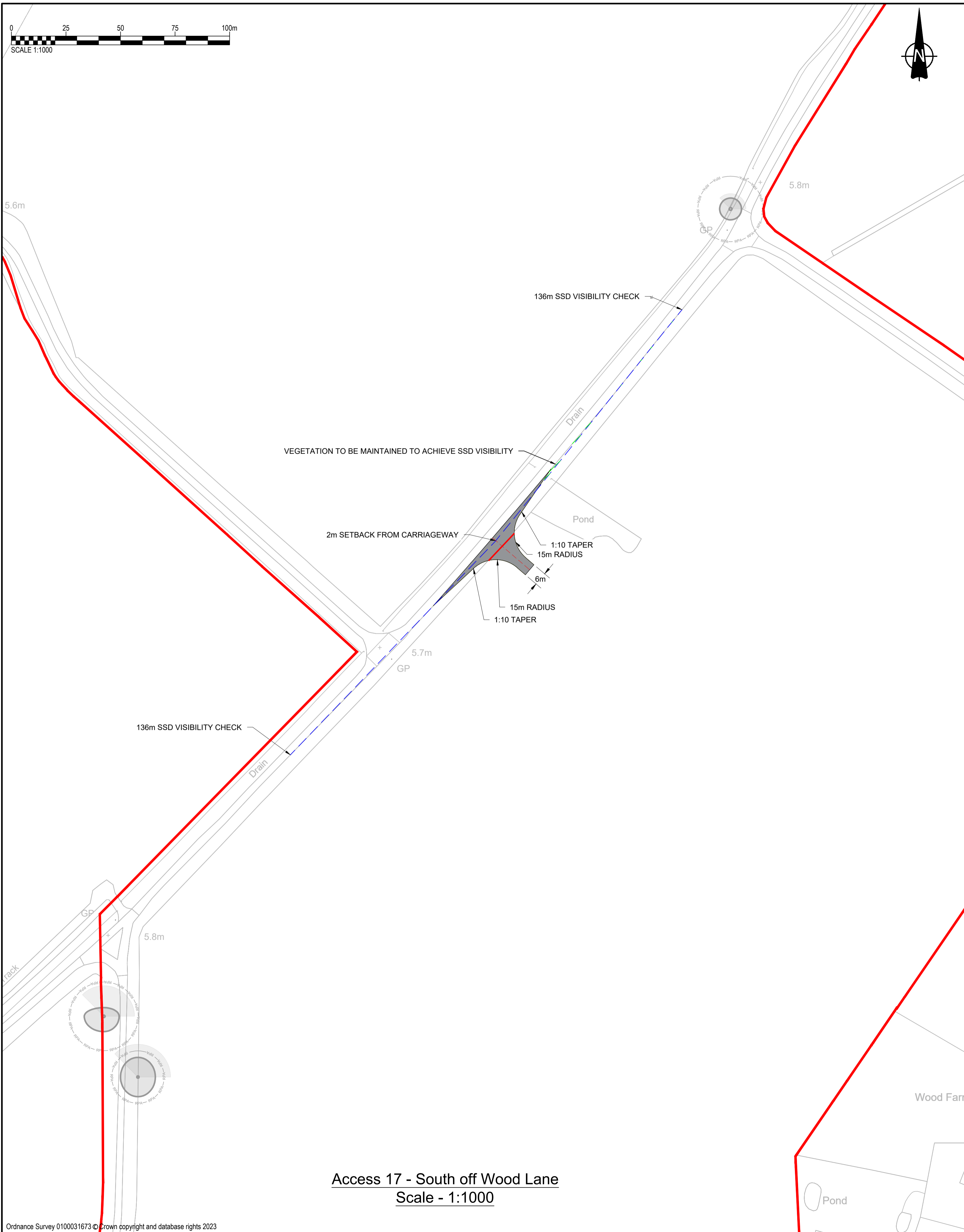

**Access 17 - South off Wood Lane**  
 Scale - 1:1000

Farm tractor & hay wagon 12.0m	18.820m
Overall Length	2.500m
Overall Width	0.438m
Min Body Ground Clearance	0.380m
Max Track Width	2.500m
Lock to lock time	4.00s
Kerb to Kerb Turning Radius	4.620m

INSET A: FARM TRACTOR AND HAY WAGON MANOEUVRE HEADING EAST ON WOOD LANE, RIGHT TURN INTO ACCESS - SCALE 1:1000

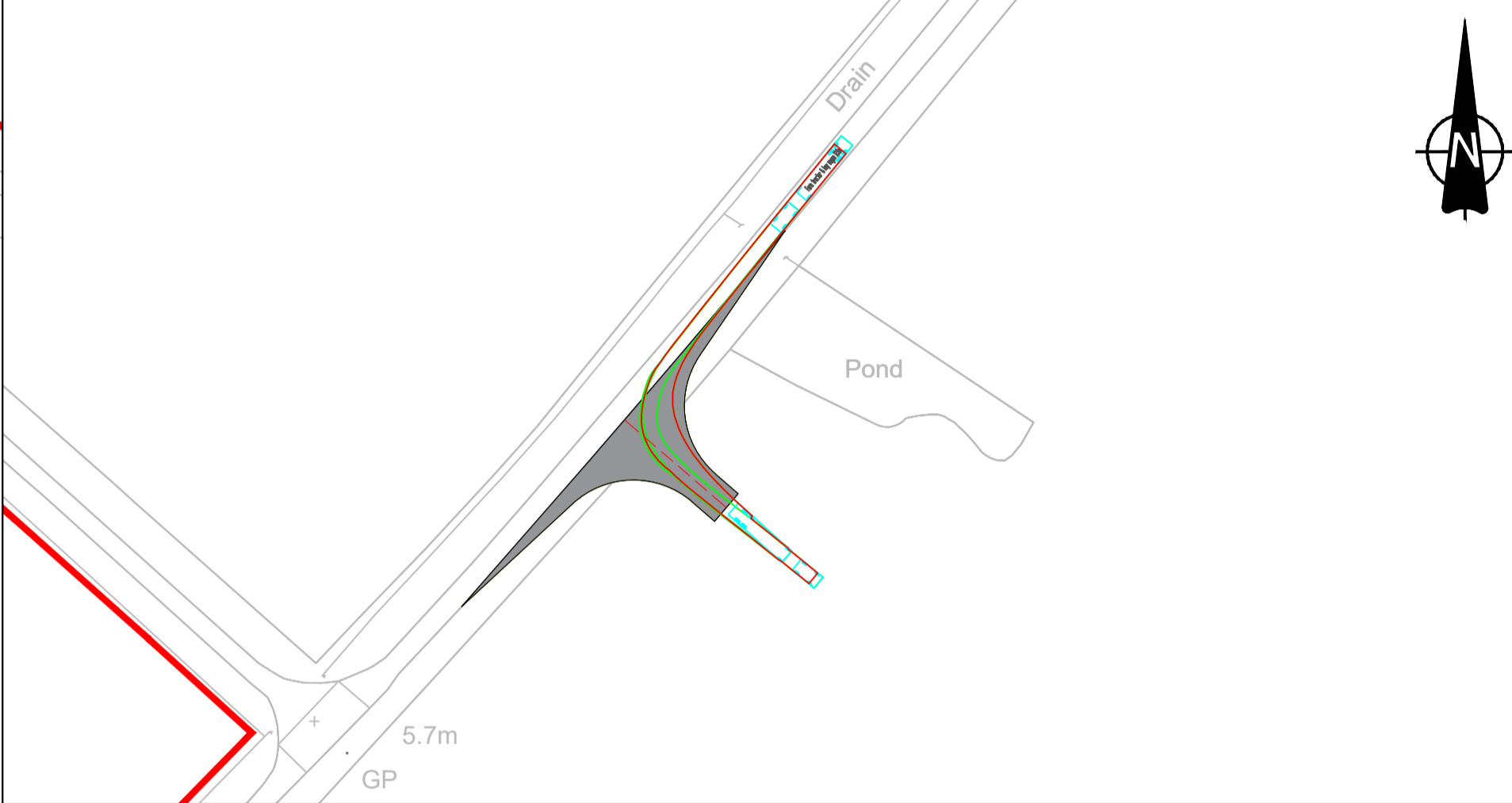

INSET B: FARM TRACTOR AND HAY WAGON MANOEUVRE HEADING WEST ON WOOD LANE, LEFT TURN INTO ACCESS - SCALE 1:1000

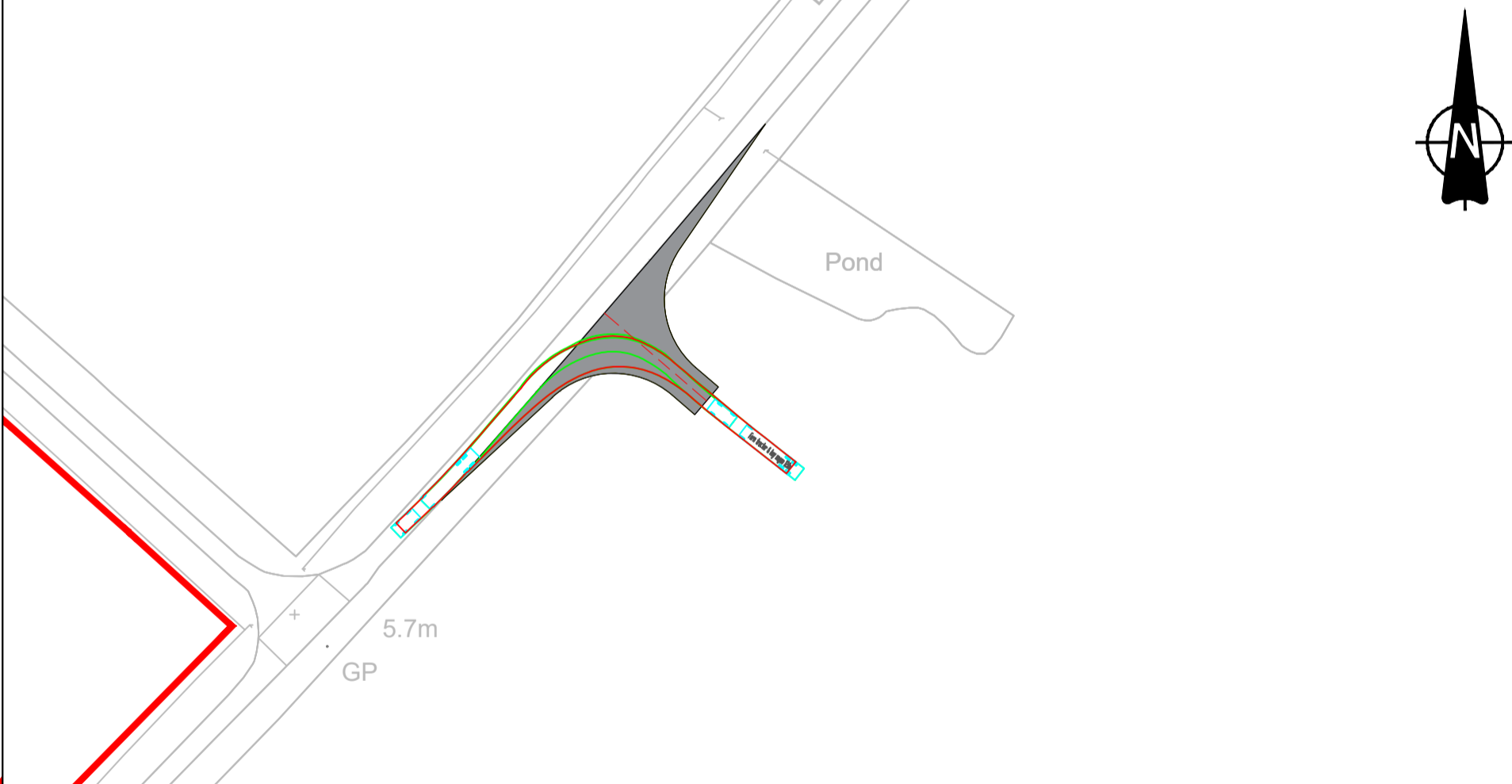

INSET C: FARM TRACTOR AND HAY WAGON MANOEUVRE LEFT TURN OUT OF ACCESS ONTO WOOD LANE HEADING WEST - SCALE 1:1000

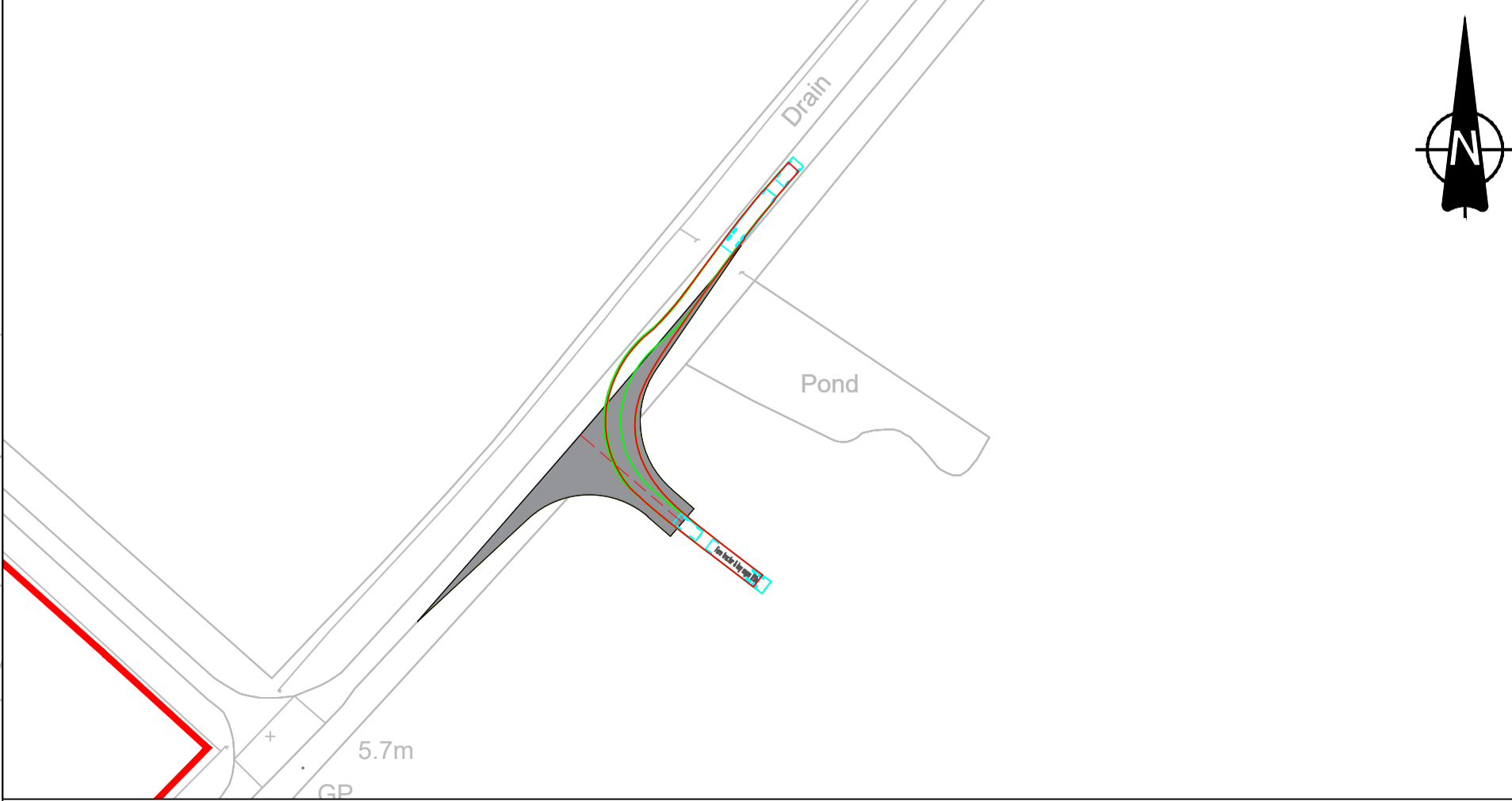

INSET D: FARM TRACTOR AND HAY WAGON MANOEUVRE RIGHT TURN OUT OF ACCESS ONTO WOOD LANE HEADING EAST - SCALE 1:1000



**PROJECT**  
 East Yorkshire Solar Farm  
 Development Consent Order

**CLIENT**  
 EAST YORKSHIRE SOLAR FARM LIMITED

**CONSULTANT**  
 AECOM  
 Saxon House, 27 Duke Street  
 Chelmsford, Essex, CM1 1HT  
 01245 771200 tel 01245 476121 fax  
 www.aecom.com

- GENERAL NOTES**
1. This drawing is to be read in conjunction with all other relevant documentation.
  2. Do not scale from this drawing, use only printed dimensions.
  3. All dimensions in millimeters, all chainages, levels and coordinates are in meters unless defined otherwise.
  4. This Drawing is to be read in conjunction with the project health & Safety File for any identified potential risks.
  5. Vegetation to be removed denotes any vegetation features (such as hedgerows) that need to be removed to provide the required junction visibility. Any verge grassland is not to be removed but managed by the relevant maintainer to a low height so as to not impact upon junction visibility.
  6. Junction visibility for the access is based upon visibility parameters derived using 85th Percentile Speed Survey received on 27th July 2023.
  7. Passing place requirement and location subject to ongoing discussion and agreement with East Riding of Yorkshire.

- KEY**
- Extent of Access Footprint
  - Red Line Boundary
  - Existing Public Rights of Way
  - Vehicle body
  - Vehicle body path
  - Vehicle load
  - Vehicle load path
  - Vehicle wheels path
  - Edge of road
  - Land not included in the Order Limits
  - Junction Visibility
  - Vegetation Management for Vis Splay
  - Hedgerow Removal for Bellmouth Access

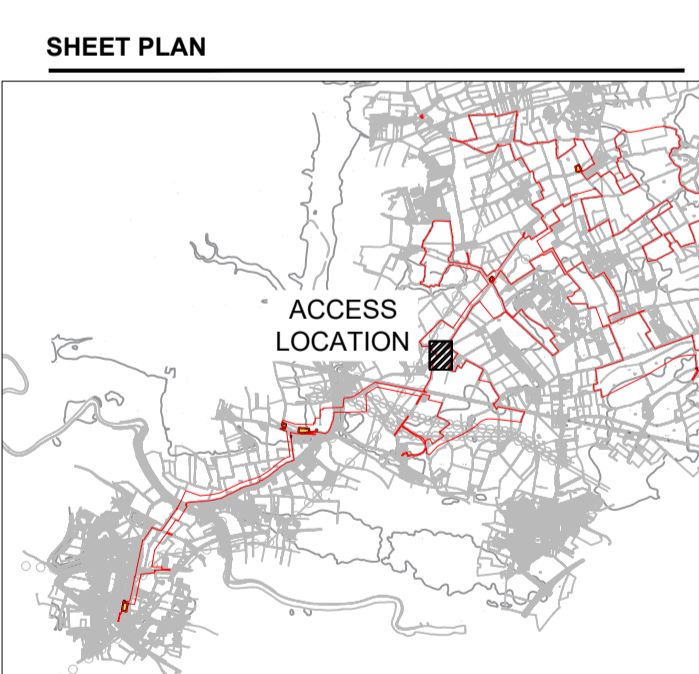

**ISSUE/REVISION**

NO	DATE	DESCRIPTION
P03	27-10-2023	Final DCO Submission
P02	15-09-2023	Updated Post Internal Review
P01	25-08-2023	Issued for internal review
I/R	DATE	DESCRIPTION

**PROJECT NUMBER**  
 60686115

**SHEET TITLE**  
 ACCESS 17 SOUTH OFF WOOD LANE LAYOUT AND SWEEP PATH ANALYSIS

**SHEET NUMBER**  
 60686115-HGN-DR-CH-0117

This drawing has been prepared for the use of AECOM's client. It may not be used, modified, reproduced or relied upon by third parties, except as agreed by AECOM or as required by law. AECOM accepts no responsibility, and denies any liability whatsoever, to any party that uses or relies on this drawing without AECOM's express written consent. Do not scale this document.



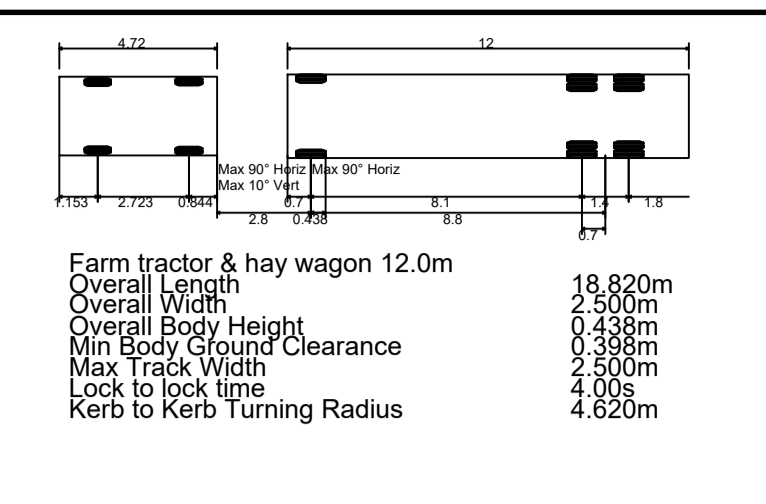

INSET A: TRACTOR & HAY WAGON MANOEUVRE HEADING NORTH ON THE ROWLANDHALL LANE, RIGHT TURN INTO ACCESS - SCALE 1:1000



INSET B: TRACTOR & HAY WAGON MANOEUVRE HEADING SOUTH ON ROWLANDHALL LANE, LEFT TURN INTO ACCESS - SCALE 1:1000

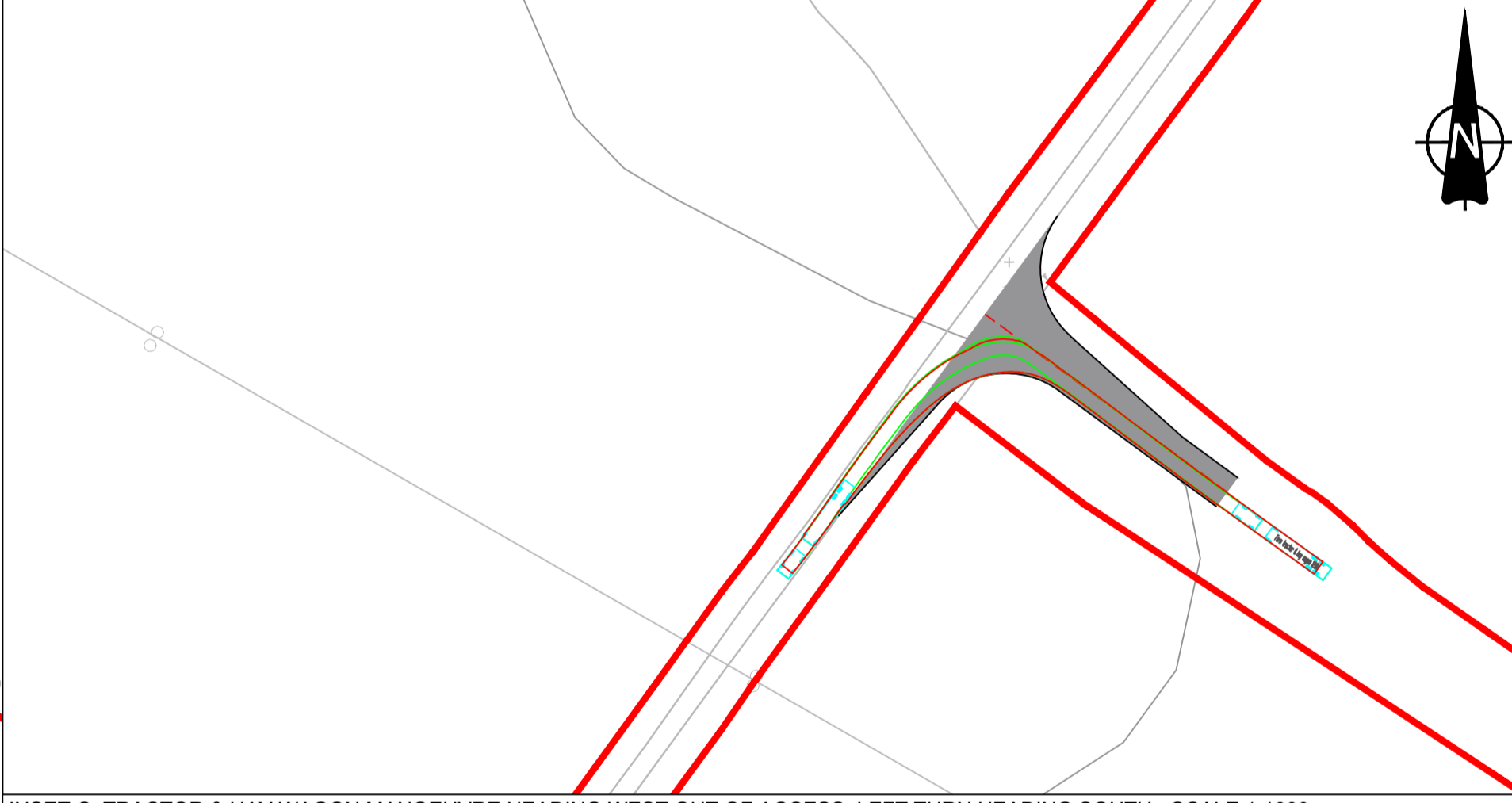

INSET C: TRACTOR & HAY WAGON MANOEUVRE HEADING WEST OUT OF ACCESS, LEFT TURN HEADING SOUTH - SCALE 1:1000

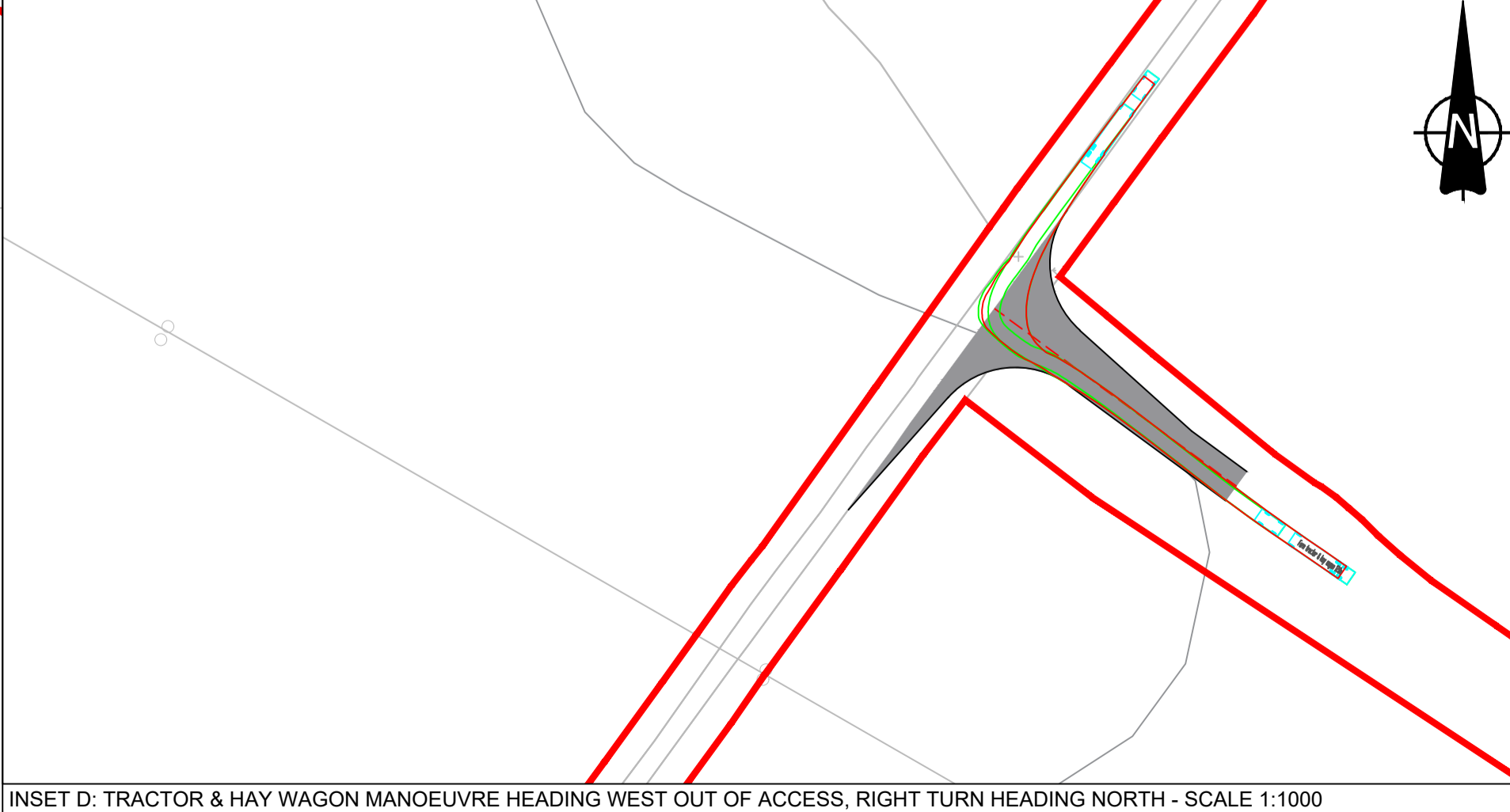

INSET D: TRACTOR & HAY WAGON MANOEUVRE HEADING WEST OUT OF ACCESS, RIGHT TURN HEADING NORTH - SCALE 1:1000

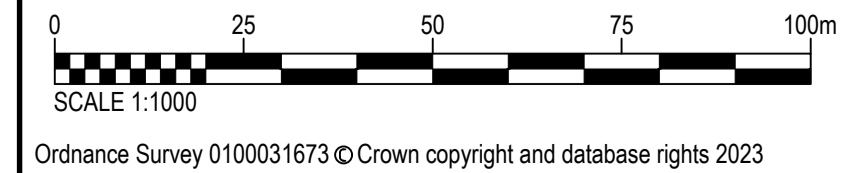

Access 18 - East off Rowlandhall Lane  
Scale - 1:1000



**PROJECT**  
 East Yorkshire Solar Farm  
 Development Consent Order

**CLIENT**  
 East Yorkshire Solar Farm Limited

**CONSULTANT**  
 AECOM  
 Saxon House, 27 Duke Street  
 Chelmsford, Essex, CM1 1HT  
 01245 771200 tel 01245 476121 fax  
 www.aecom.com

- GENERAL NOTES**
1. This drawing is to be read in conjunction with all other relevant documentation.
  2. Do not scale from this drawing, use only printed dimensions.
  3. All dimensions in millimeters, all chainages, levels and coordinates are in meters unless defined otherwise.
  4. This Drawing is to be read in conjunction with the project health & Safety File for any identified potential risks.
  5. Vegetation to be removed denotes any vegetation features (such as hedgerows) that need to be removed to provide the required junction visibility. Any verge grassland is not to be removed but managed by the relevant maintainer to a low height so as to not impact upon junction visibility.
  6. Junction Visibility for the access is based upon DMRB CD109 Table 2.10.
  7. Passing place requirement and location subject to ongoing discussion and agreement with East Riding of Yorkshire.

- KEY**
- Extent of Access Footprint
  - Red Line Boundary
  - Existing Public Rights of Way
  - Vehicle body
  - Vehicle body path
  - Vehicle load
  - Vehicle load path
  - Vehicle wheels path
  - Edge of road
  - Land not included in the Order Limits
  - Junction Visibility
  - Vegetation Management for Vis Splay
  - Hedgerow Removal for Bellmouth Access

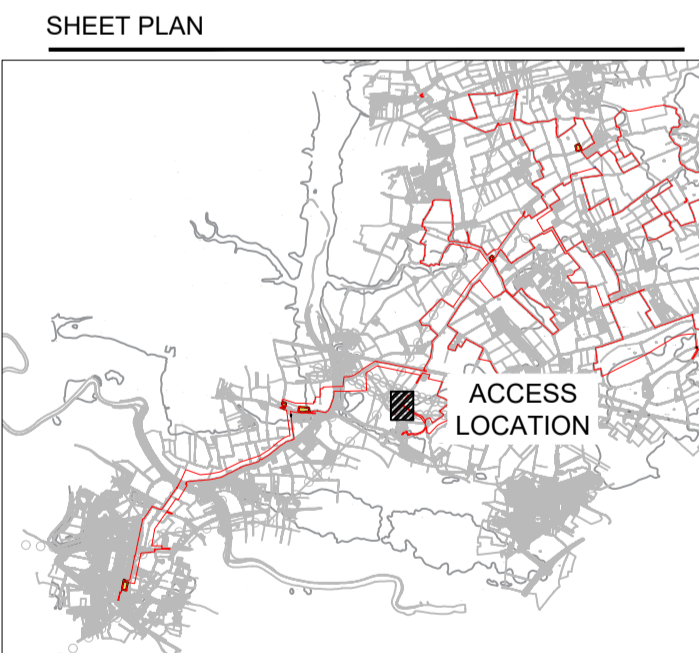

**ISSUE/REVISION**

NO	DATE	DESCRIPTION
P03	27-10-2023	Final DCO Submission
P02	15-09-2023	Updated Post Internal Review
P01	25-08-2023	Issued for Internal Review
I/R	DATE	DESCRIPTION

**PROJECT NUMBER**  
 60686115

**SHEET TITLE**  
 ACCESS 18 EAST OFF ROWLANDHALL LANE LAYOUT AND SWEPT PATH ANALYSIS

**SHEET NUMBER**  
 60686115-HGN-DR-CH-0118

This drawing has been prepared for the use of AECOM's client. It may not be used, modified, reproduced or relied upon by third parties, except as agreed by AECOM or as required by law. AECOM accepts no responsibility, and denies any liability whatsoever, to any party that uses or relies on this drawing without AECOM's express written consent. Do not scale this document.

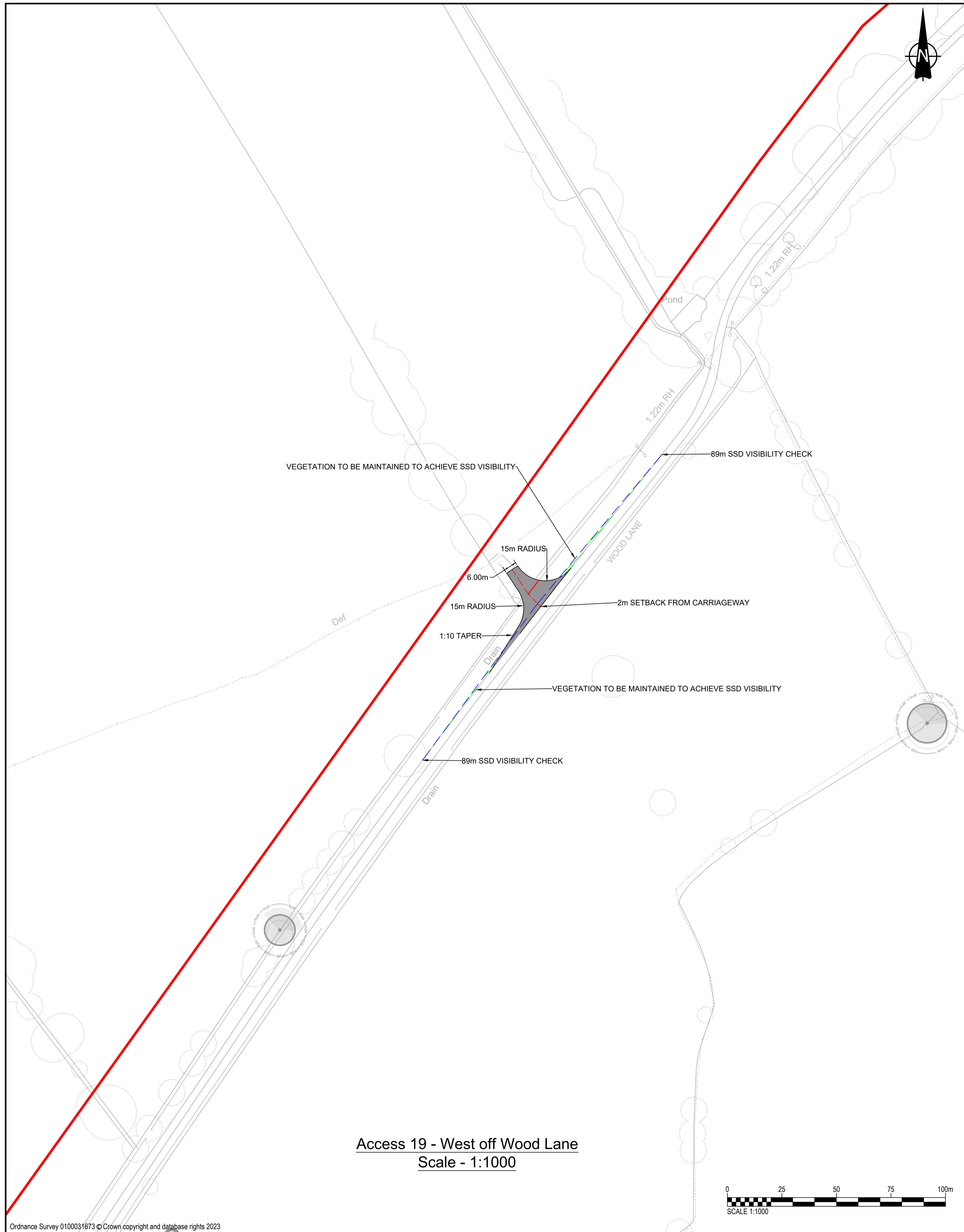

Farm tractor & hay wagon 12.0m	18.820m
Overall Length	2.500m
Overall Width	0.438m
Min Body Ground Clearance	0.398m
Max Trunk Width	2.500m
Lock to lock time	4.00s
Kerb to Kerb Turning Radius	4.620m

INSET A: TRACTOR & HAY WAGON MANOEUVRE HEADING SOUTH ON WOOD LANE, RIGHT TURN INTO ACCESS - SCALE 1:1000



INSET B: TRACTOR & HAY WAGON MANOEUVRE HEADING NORTH ON WOOD LANE, LEFT TURN INTO ACCESS - SCALE 1:1000

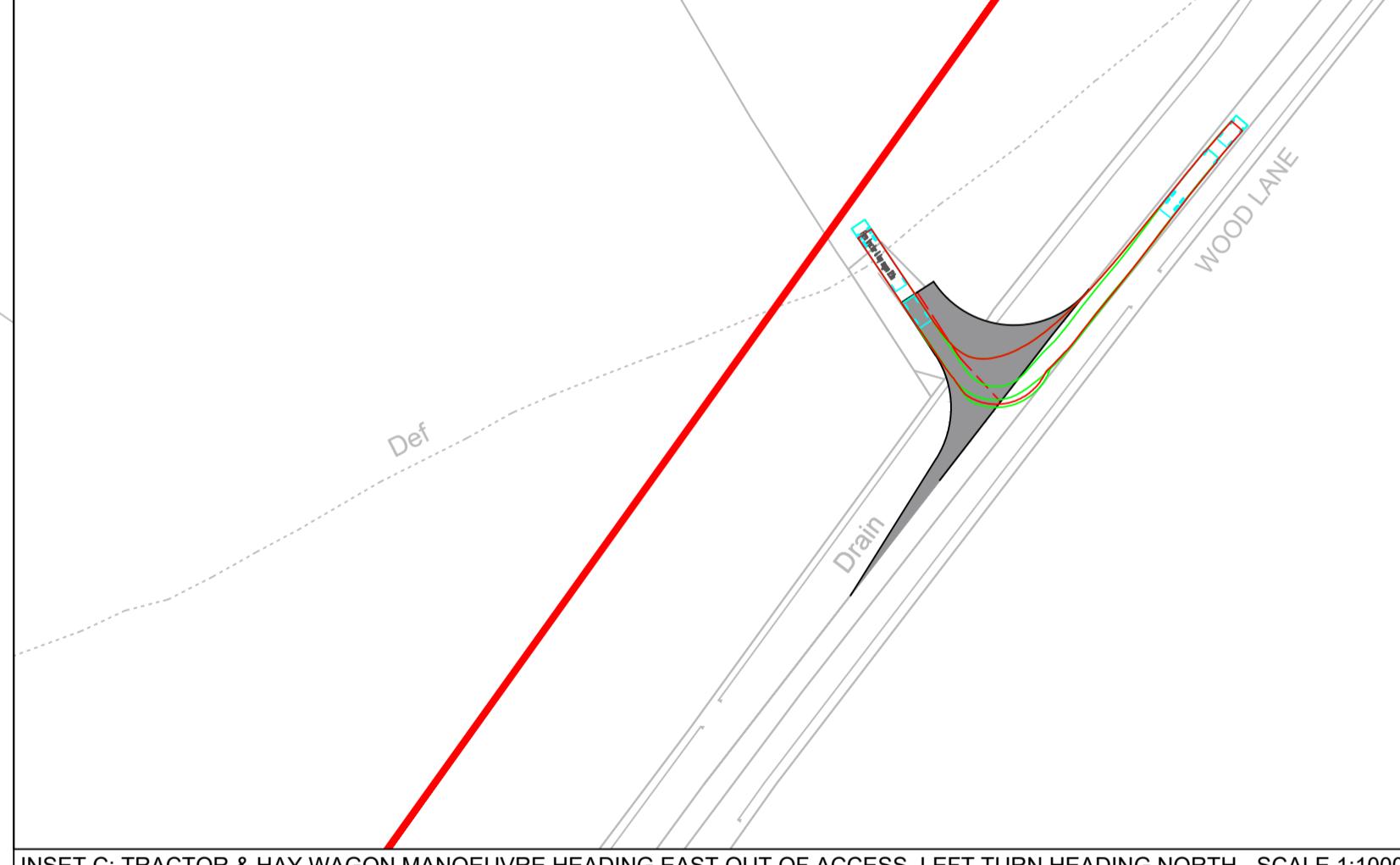

INSET C: TRACTOR & HAY WAGON MANOEUVRE HEADING EAST OUT OF ACCESS, LEFT TURN HEADING NORTH - SCALE 1:1000

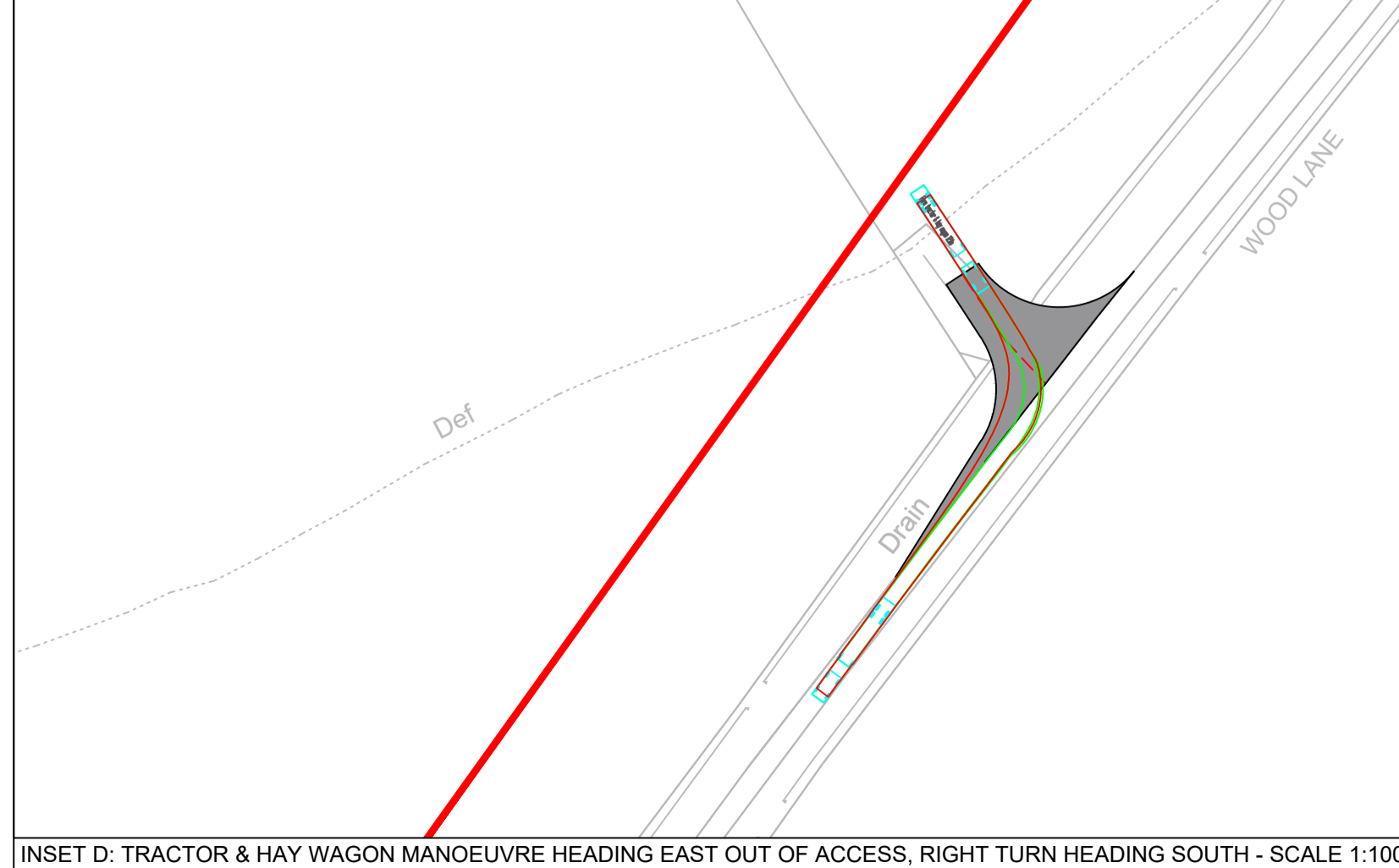

INSET D: TRACTOR & HAY WAGON MANOEUVRE HEADING EAST OUT OF ACCESS, RIGHT TURN HEADING SOUTH - SCALE 1:1000

- GENERAL NOTES**
1. This drawing is to be read in conjunction with all other relevant documentation.
  2. Do not scale from this drawing, use only printed dimensions.
  3. All dimensions in millimeters, all chainages, levels and coordinates are in meters unless defined otherwise.
  4. This Drawing is to be read in conjunction with the project health & Safety File for any identified potential risks.
  5. Vegetation to be removed denotes any vegetation features (such as hedgerows) that need to be removed to provide the required junction visibility. Any verge grassland is not to be removed but managed by the relevant maintainer to a low height so as to not impact upon junction visibility.
  6. Junction visibility for the access is based upon visibility parameters derived using 85th Percentile Speed Survey received on 27th July 2023.
  7. Passing place requirement and location subject to ongoing discussion and agreement with East Riding of Yorkshire.

**KEY**

- Extent of Access Footprint
- Red Line Boundary
- Existing Public Rights of Way
- Vehicle body
- Vehicle body path
- Vehicle load
- Vehicle load path
- Vehicle wheels path
- Edge of road
- Land not included in the Order Limits
- Junction Visibility
- Vegetation Management for Vis Splay
- Hedgerow Removal for Bellmouth Access

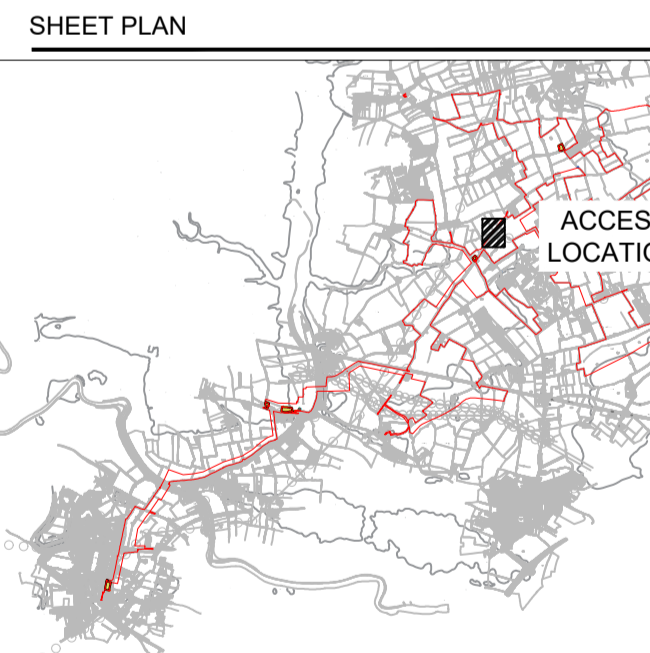

**ISSUE/REVISION**

I/R	DATE	DESCRIPTION
P03	27-10-2023	Final DCO Submission
P02	15-09-2023	Updated Post Internal Review
P01	07-09-2023	Issued for internal review

This drawing has been prepared for the use of AECOM's client. It may not be used, modified, reproduced or relied upon by third parties, except as agreed by AECOM or as required by law. AECOM accepts no responsibility, and denies any liability whatsoever, to any party that uses or relies on this drawing without AECOM's express written consent. Do not scale this document.

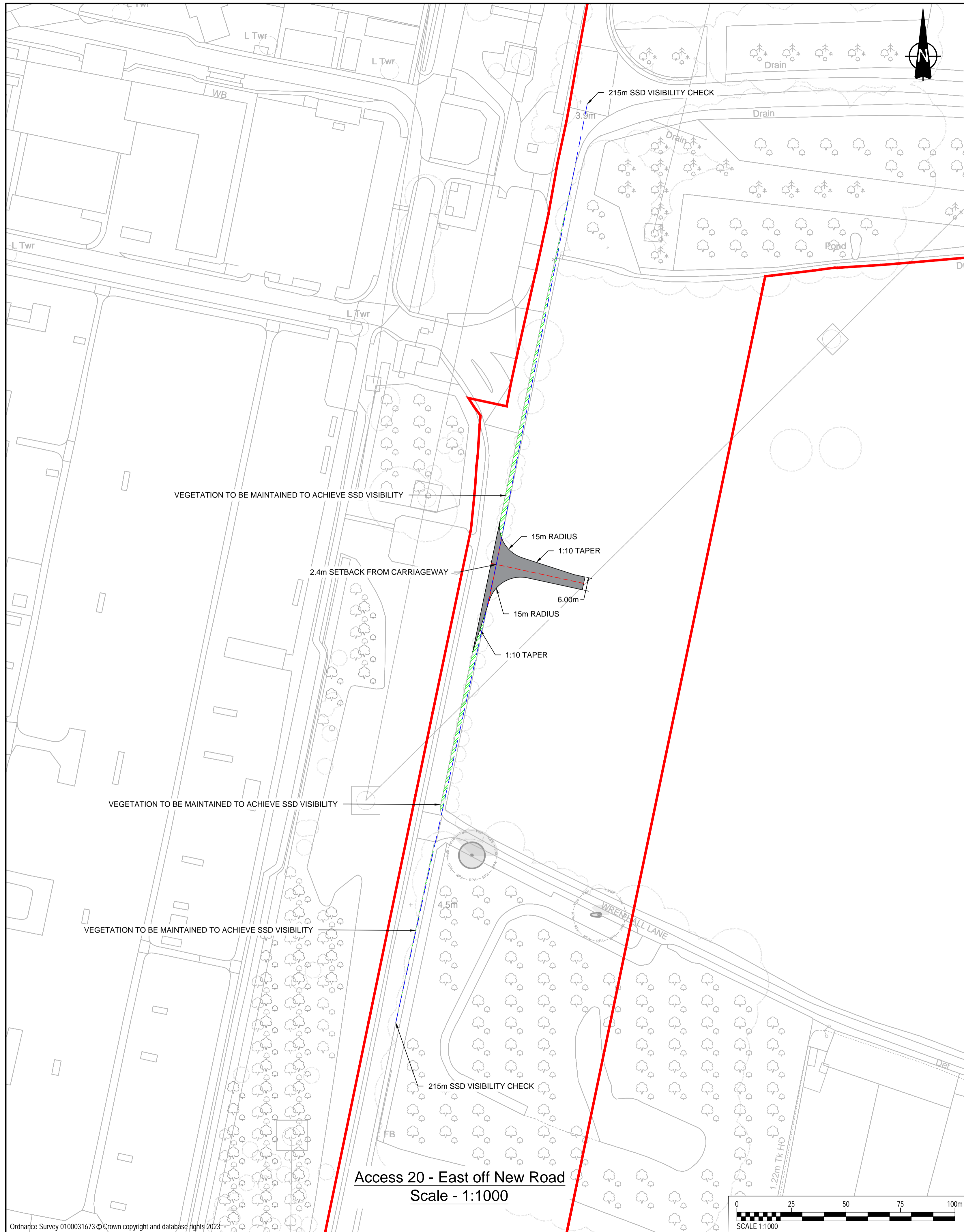

Farm tractor & hay wagon 12.0m	18.820m
Overall Length	2.500m
Overall Width	0.438m
Min Body Ground Clearance	0.398m
Max Track Width	2.500m
Lock to lock time	4.00s
Kerb to Kerb Turning Radius	4.620m



**PROJECT**  
 East Yorkshire Solar Farm  
 Development Consent Order

**CLIENT**  
 East Yorkshire Solar Farm Limited

**CONSULTANT**  
 AECOM  
 Saxon House, 27 Duke Street  
 Chelmsford, Essex, CM1 1HT  
 01245 771200 tel 01245 476121 fax  
 www.aecom.com

- GENERAL NOTES**
1. This drawing is to be read in conjunction with all other relevant documentation.
  2. Do not scale from this drawing, use only printed dimensions.
  3. All dimensions in millimeters, all chainages, levels and coordinates are in meters unless defined otherwise.
  4. This Drawing is to be read in conjunction with the project health & Safety File for any identified potential risks.
  5. Vegetation to be removed denotes any vegetation features (such as hedgerows) that need to be removed to provide the required junction visibility. Any verge grassland is not to be removed but managed by the relevant maintainer to a low height so as to not impact upon junction visibility.
  6. Junction Visibility for the access is based upon DMRB CD109 Table 2.10.

- KEY**
- Extent of Access Footprint
  - Red Line Boundary
  - Existing Public Rights of Way
  - Vehicle body
  - Vehicle body path
  - Vehicle load
  - Vehicle load path
  - Vehicle wheels path
  - Edge of road
  - Land not included in the Order Limits
  - Junction Visibility
  - Vegetation Management for Vis Splay
  - Hedgerow Removal for Bellmouth Access

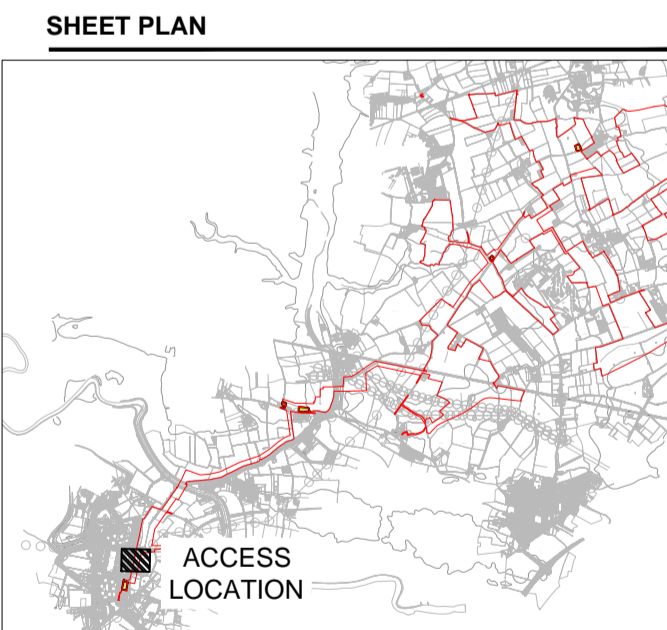

**ISSUE/REVISION**

NO	DATE	DESCRIPTION
P04	09-11-2023	Updated Post NYC Consultation
P03	27-10-2023	Final DCO Submission
P02	15-09-2023	Updated Post Internal Review
P01	04-09-2023	Issued for internal review
I/R	DATE	DESCRIPTION

**PROJECT NUMBER**  
 60686115

**SHEET TITLE**  
 ACCESS 20 EAST OFF NEW ROAD  
 LAYOUT AND  
 SWEPT PATH ANALYSIS

**SHEET NUMBER**  
 60686115-HGN-DR-CH-0120

This drawing has been prepared for the use of AECOM's client. It may not be used, modified, reproduced or relied upon by third parties, except as agreed by AECOM or as required by law. AECOM accepts no responsibility, and denies any liability whatsoever, to any party that uses or relies on this drawing without AECOM's express written consent. Do not scale this document.